

电池护照

Passport ID :

TP_BAT_2025_E36100B_08020000

1. 基本信息 (General Info)

型号 (Model Number)	E36100B-ST1
序列号 (Serial Number)	ST1VBB24080057
类别 (Category)	LMT
制造日期 (Manufactured Date)	2024/8/2
状态 (Status)	Original
重量 (Weight)	2.45 Kg
标称电压 (Nominal Voltage)	36.9 V
标称容量 (Nominal Capacity)	9.6 Ah
制造商 (Manufactured by)	Shenzhen Topband Co.,Ltd

2. 性能与耐久性 (Performance & Durability)

电池状态 (Battery condition information)

能量 (Energy Throughput)	10800 Wh
容量 (Capacity Throughput)	290 Ah
50%寿命循环后电池健康度 (Round Trip energy efficiency at 50% of cycle-life)	88%
完全循环次数 (Number of Full Cycle)	30 cycles
容量衰减 (Capacity Fade)	1%
功率衰减 (Power Fade)	0.50%
剩余容量 (Remaining Capacity)	8.64 AH
充电状态 (State of Charge)	90%
剩余能量效率 (Remaining Roundtrip Energy Efficiency)	99%
自放电率 (Self Discharging Rate)	0.2%/month
内阻 (Internal Resistance)	≤ 130 m Ω
内阻增加 (Increased Internal Resistance)	1%
外部温度下待机时间 (The Stand-by Spent in Extern Temp)	0 Min
外部温度下充电时间 (The Charge Time Spent in Extern Temp)	0 Min
外部温度下放电时间 (The Discharge Time Spent in Extern Temp)	0 Min
深度放电次数 (The Numbers of Deep Discharge)	0 Times

3. 电池技术特性 (Battery Technical Property)

额定最大功率 (Rated Maximum Power)	553 W
额定能量 (Rated Energy)	354.24 Wh
预期循环次数 (Expected Number of Cycles)	600 cycle
额定容量 (Rated Capacity)	9.6 Ah
预期寿命 (Expected Lifetime)	2.5 Years
标称电压 (Nominal Voltage)	36.9 V
最小电压 (Minimum Voltage)	27 V
最大电压 (Maximum Voltage)	42 V
工作温度 (Operating Temperature)	-20 °C to 50 °C
初始自放电 (Initial Self Discharge)	2%/month
初始冲放电效率 (Initial Round Trip Efficiency)	95%

4. Regulatory Documents 1542

见附件 (Please refer to the attachment)	
--------------------------------------	--

5. Functional Safety ISO 13849

见附件 (Please refer to the attachment)	
--------------------------------------	--



6. LMT Safety Test EN 50604

见附件 (Please refer to the attachment)	
--------------------------------------	--

7. Label



Prüfbericht - Produkte
Test Report - Products

Prüfbericht-Nr.: Test report no.:	CN24XK5W 001	Auftrags-Nr.: Order no.:	168497397	Seite 1 von 27 Page 1 of 27
Kunden-Referenz-Nr.: Client reference no.:	N/A	Auftragsdatum: Order date:	2024-07-04	
Auftraggeber: Client:	Shenzhen Topband Co., Ltd 1F, the Second Phase of Topband Industrial Park, No.2 Sci-Tech Road, Tangtou Community, Shiyan Street, Baoan District, Shenzhen, P.R. China			
Prüfgegenstand: Test item:	Li-ion Battery pack			
Bezeichnung / Typ-Nr.: Identification / Type no.:	E36100B-ST1			
Auftrags-Inhalt: Order content:	Test report			
Prüfgrundlage: Test specification:	REGULATION (EU) 2023/1542 OF THE EUROPEAN PARLIAMENT AND OF THE COUNCIL of 12 July 2023			
Wareneingangsdatum: Date of sample receipt:	2024-08-05	See Attachment 2 for photo documentation		
Prüfmuster-Nr.: Test sample no.:	A003824149-017			
Prüfzeitraum: Testing period:	2024-09-24 - 2024-10-31			
Ort der Prüfung: Place of testing:	TÜV Rheinland (Shenzhen) Co., Ltd.			
Prüflaboratorium: Testing laboratory:	TÜV Rheinland (Shenzhen) Co., Ltd.			
Prüfergebnis*: Test result*:	Pass			
erstellt von: created by:		genehmigt von: authorized by:		
Datum: Date:	2024-12-12	Ausstellungsdatum: Issue date:	2024-12-12	
Stellung / Position:	Project Engineer	Stellung / Position:	Authorizer	
Sonstiges / <i>Other:</i>	Article 6, 10, 14, 19-20 of (EU) 2023/1542 evaluated in this report, valid until 2025.08.17 This report does not evidence compliance of the provided sample with the relevant standards but only with the referred tests. This test report documents the findings of examination conducted on the delivered product mentioned above only. This report does not entitle the applicant to carry any safety mark on this or similar products. Further for sales or other application purposes of the tested product, any reference to TÜV Rheinland or a test through TÜV Rheinland is only permissible with prior written consent of TÜV Rheinland.			
Zustand des Prüfgegenstandes bei Anlieferung: Condition of the test item at delivery:	Prüfmuster vollständig und unbeschädigt Test item complete and undamaged			
* Legende:	P(ass) = entspricht o.g. Prüfgrundlage(n)	F(ail) = entspricht nicht o.g. Prüfgrundlage(n)	N/A = nicht anwendbar	N/T = nicht getestet
* Legend:	P(ass) = passed a.m. test specification(s)	F(ail) = failed a.m. test specification(s)	N/A = not applicable	N/T = not tested
Dieser Prüfbericht bezieht sich nur auf das o.g. Prüfmuster und darf ohne Genehmigung der Prüfstelle nicht auszugsweise vervielfältigt werden. Dieser Bericht berechtigt nicht zur Verwendung eines Prüfzeichens. <i>This test report only relates to the above mentioned test sample. Without permission of the test center this test report is not permitted to be duplicated in extracts. This test report does not entitle to carry any test mark.</i>				

TÜV Rheinland (Shenzhen) Co., Ltd., 1601-1604, 17-18F, Tower A Building 2, Shenzhen International Innovation Valley, Dashi 1st Road, Xili Street, Xili Community, Nanshan District, Shenzhen 518052, P.R. China

Mail: service-gc@tuv.com · Web: www.tuv.com

Prüfbericht-Nr.: CN24XK5W 001
Test report no.:

Seite 2 von 27
Page 2 of 27

Anmerkungen
Remarks

1	<p>Alle eingesetzten Prüfmittel waren zum angegebenen Prüfzeitraum gemäß eines festgelegten Kalibrierungsprogramms unseres Prüfhauses kalibriert. Sie entsprechen den in den Prüfprogrammen hinterlegten Anforderungen. Die Rückverfolgbarkeit der eingesetzten Prüfmittel ist durch die Einhaltung der Regelungen unseres Managementsystems gegeben. Detaillierte Informationen bezüglich Prüfkonditionen, Prüfequipment und Messunsicherheiten sind im Prüflabor vorhanden und können auf Wunsch bereitgestellt werden.</p> <p><i>The equipment used during the specified testing period was calibrated according to our test laboratory calibration program. The equipment fulfils the requirements included in the relevant standards. The traceability of the test equipment used is ensured by compliance with the regulations of our management system. Detailed information regarding test conditions, equipment and measurement uncertainty is available in the test laboratory and could be provided on request.</i></p>
2	<p>Wie vertraglich vereinbart, wurde dieses Dokument nur digital unterzeichnet. Der TÜV Rheinland hat nicht überprüft, welche rechtlichen oder sonstigen diesbezüglichen Anforderungen für dieses Dokument gelten. Diese Überprüfung liegt in der Verantwortung des Benutzers dieses Dokuments. Auf Verlangen des Kunden kann der TÜV Rheinland die Gültigkeit der digitalen Signatur durch ein gesondertes Dokument bestätigen. Diese Anfrage ist an unseren Vertrieb zu richten. Eine Umweltgebühr für einen solchen zusätzlichen Service wird erhoben. Informationen zur Verifizierung der Authentizität unserer Dokumente erhalten Sie auf folgender Webseite: go.tuv.com/digital-signature</p> <p><i>As contractually agreed, this document has been signed digitally only. TUV Rheinland has not verified and unable to verify which legal or other pertaining requirements are applicable for this document. Such verification is within the responsibility of the user of this document. Upon request by its client, TUV Rheinland can confirm the validity of the digital signature by a separate document. Such request shall be addressed to our Sales department. An environmental fee for such additional service will be charged. For information on verifying the authenticity of our documents, please visit the following website: go.tuv.com/digital-signature</i></p>
3	<p>Prüfklausel mit der Note * wurden an qualifizierte Unterauftragnehmer vergeben und sind unter der jeweiligen Prüfklausel des Berichts beschrieben. Abweichungen von Prüfspezifikation(en) oder Kundenanforderungen sind in der jeweiligen Prüfklausel im Bericht aufgeführt.</p> <p><i>Test clauses with remark of * are subcontracted to qualified subcontractors and described under the respective test clause in the report. Deviations of testing specification(s) or customer requirements are listed in specific test clause in the report.</i></p>
4	<p>Die Entscheidungsregel für Konformitätserklärungen basierend auf numerischen Messergebnissen in diesem Prüfbericht basiert auf der "Null-Grenzwert-Regel" und der "Einfachen Akzeptanz" gemäß ILAC G8:2019 und IEC Guide 115:2021, es sei denn, in der auf Seite 1 dieses Berichts genannten angewandten Norm ist etwas anderes festgelegt oder vom Kunden gewünscht. Dies bedeutet, dass die Messunsicherheit nicht berücksichtigt wird und daher auch nicht im Prüfbericht angegeben wird. Zu weiteren Informationen bezüglich des Risikos durch diese Entscheidungsregel siehe ILAC G8:2019.</p> <p><i>The decision rule for statements of conformity, based on numerical measurement results, in this test report is based on the "Zero Guard Band Rule" and "Simple Acceptance" in accordance with ILAC G8:2019 and IEC Guide 115:2021, unless otherwise specified in the applied standard mentioned on Page 1 of this report or requested by the customer. This means that measurement uncertainty is not taken in account and hence also not declared in the test report. For additional information to the resulting risk based of this decision rule please refer to ILAC G8:2019.</i></p>

TEST REPORT

REGULATION (EU) 2023/1542 OF THE EUROPEAN PARLIAMENT AND OF THE COUNCIL of 12 July 2023

concerning batteries and waste batteries, amending Directive 2008/98/EC and Regulation (EU) 2019/1020 and repealing Directive 2006/66/EC

Report Number: CN24XK5W 001

Date of issue: See cover page

Total number of pages: See cover page

Testing location: TÜV Rheinland (Shenzhen) Co., Ltd.
1-5F, Block 5, No. 1100, Huanli Road, Yungu Community, Xihu Street, Guangming District, Shenzhen, China

Testing Laboratory: TÜV Rheinland (Shenzhen) Co., Ltd.

Applicant's name: See cover page

Address: See cover page

Test specification:

Standard: See cover page

Test procedure: See cover page

Non-standard test method: N/A

Test Report Form No.: Rev. 2023-08-21

Test Report Form(s) Originator: TÜV Rheinland (Shenzhen) Co., Ltd.

Master TRF: Dated 2023-09

List of Attachments (including a total number of pages in each attachment):

-Attachment 1: Chemical report 168497397c 001 (34 pages).

-Attachment 2: Photo documentation (6 pages).

Test item particulars:

Information about the product needed to establish a correct test program, such as product mobility, type of power connections and similar.	(Test item particulars are selected by the TRF Originator base on the requirements in the standard)
Test item description.....	Rechargeable Li-ion Battery pack
Battery Category	Li-ion Battery pack
Trade mark.....	N/A
Manufacturer	TOPBAND SMART DONG NAI (VIET NAM) COMPANY LIMITED Lot D, Loc An-Binh Son Industrial Park, Long An Commune, Long Thanh District, Dong Nai Province, Viet Nam
Factory	Same as manufacturer
Model/Type reference	E36100B-ST1
Portable battery of general use	<input type="checkbox"/> Yes <input checked="" type="checkbox"/> No
Stationary battery energy storage system	<input type="checkbox"/> Yes <input checked="" type="checkbox"/> No

General remarks:

This report shall not be reproduced, except in full, without the written approval of the testing laboratory.

The test results presented in this report relate only to the object tested.

"(see remark #)" refers to a remark appended to the report.

"(see appended table)" refers to a table appended to the report.

Throughout this report a point is used as the decimal separator.

General product information and other remarks:

The battery E36100B-ST1 is constructed with twenty Li-ion cells (10S2P), and has overcharge, over-discharge, over current and short-circuits proof circuit.

The main features of the battery are shown as below:

Model	Rated capacity	Nominal voltage	Nominal Charge Current	Nominal Discharge Current	Maximum Charge Current	Maximum Discharge Current	Maximum Charge Voltage	Specified final voltage
E36100B-ST1	9.6Ah	36.9V	2.0A	7A	3.0A*	15.0A**	42.0V	28.0V

Remark:

* Maximum charging current of battery declared by manufacturer is 2880mA at 0°C to 10°C,
Maximum charging current of battery declared by manufacturer is 3000mA at 10°C to 40°C.

** Maximum discharging current of battery declared by manufacturer is 4800mA at -20°C to 10°C,
Maximum discharging current of battery declared by manufacturer is 15000mA at 10°C to 25°C,
Maximum discharging current of battery declared by manufacturer is 10000mA at 25°C to 50°C .

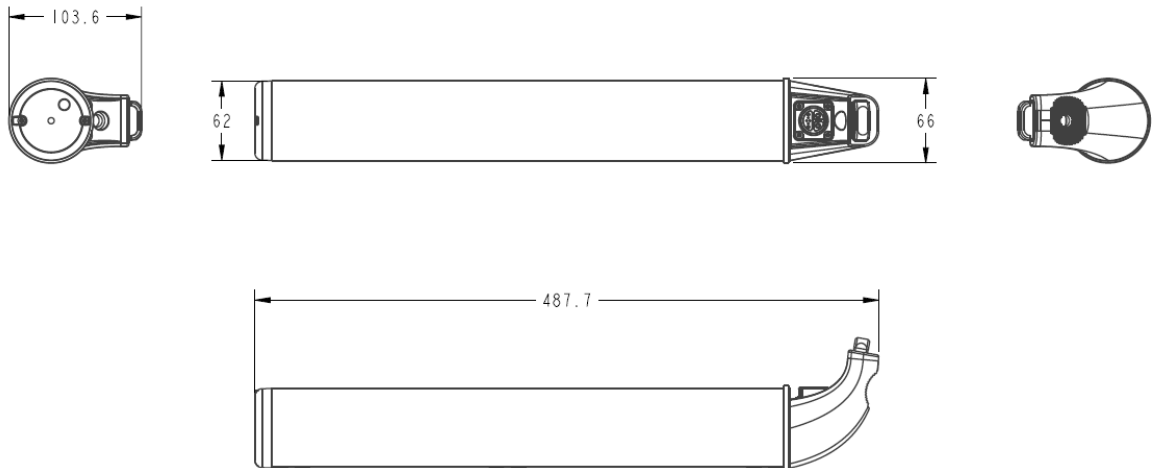
Construction:

Battery (unit: mm)

Circuit diagram:

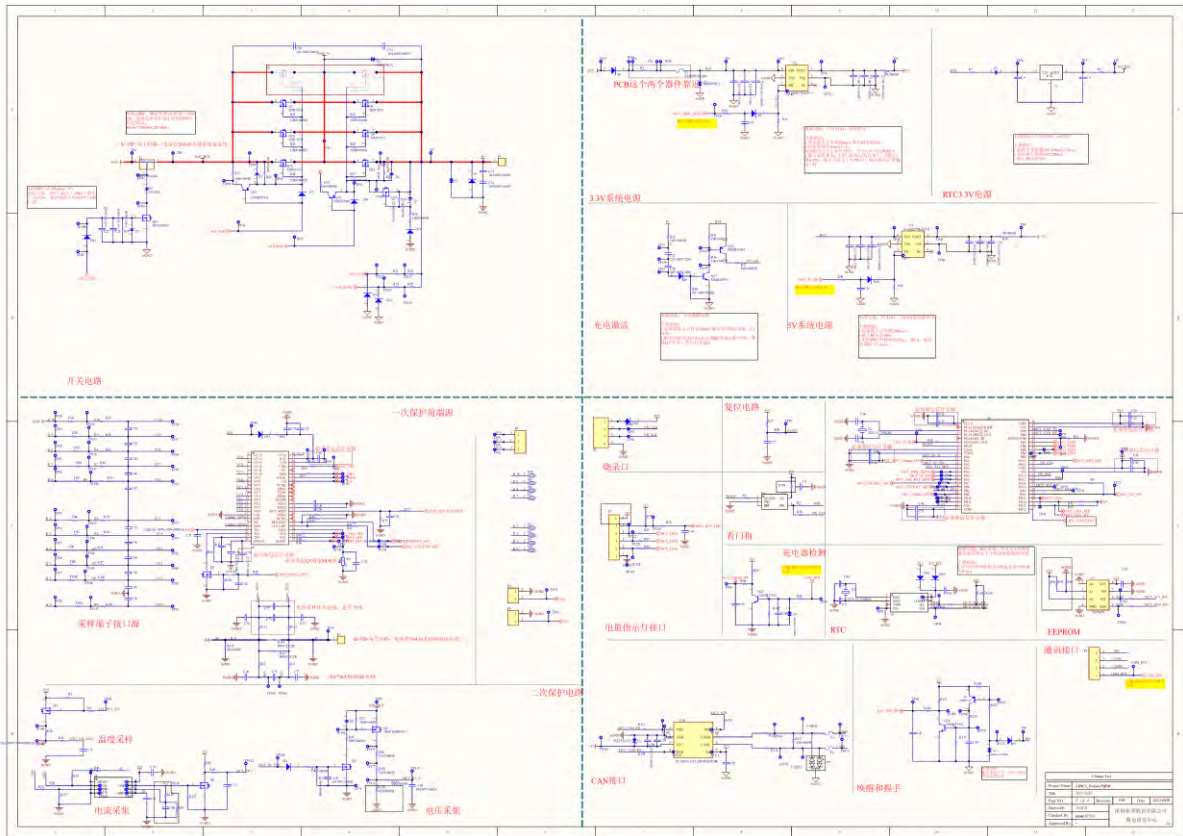

Copy of marking plate:

φ48.6

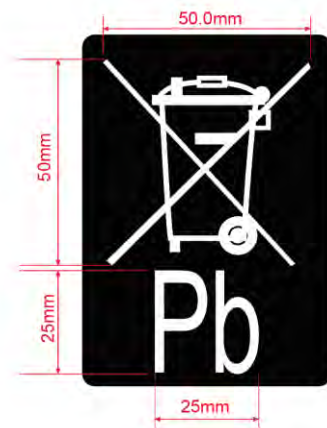

CAUTION Keep the battery far away from fire and heat source, and strictly forbidden to put it into fire. It is strictly forbidden to keep in violent vibration, shock and crush. Do not expose to water. Please connect the charge connector and charge port correctly. The battery is only for the bike you purchased and charged original charger. Don't forget to charge it for every 2 or 3 months. Do not open. Disassembly of this battery voids all warranty. Transport under UN-T 38-3. Damaged batteries are not allowed to transport. To activate the battery, it must be connected to the power supply before first use. Vor der ersten Inbetriebnahme ist der Anschluss an das Netzteil erforderlich, um den Akku zu aktivieren. Pour activer la batterie, vous devez la connecter à une source d'alimentation avant la première utilisation.

Remark:

1. The CE Marking shall be at least 5mm in height.
2. Batch Number: "ST1VBB22050001", "2205" represents the date of manufacture, "22" represents the

year, "05" represents the month.

3. Size of symbol collection symbol on battery is: 50*50mm.

(EU) 2023/1542			
Clause	Requirement + Test	Result - Remark	Verdict
Chapter I	General provisions		P
Chapter II	Sustainability and safety requirements		P
Article 6	Restrictions on substances		P
1.	In addition to the restrictions set out in Annex XVII to Regulation (EC) No 1907/2006 and in Article 4(2), point (a), of Directive 2000/53/EC, batteries shall not contain substances for which Annex I to this Regulation contains a restriction unless the conditions of that restriction are complied with.	See Attachment 1.	P
2.	In the event of an unacceptable risk to human health or the environment, arising from the use of a substance in the manufacture of batteries or from the presence of a substance in the batteries when they are placed on the market, or arising during their subsequent life cycle stages, including during repurposing or the treatment of waste batteries, that is not adequately controlled and needs to be addressed on a Union-wide basis, the Commission shall adopt a delegated act in accordance with Article 89 to amend the restrictions in Annex I, pursuant to the procedure laid down in Articles 86, 87 and 88.		P
3.	Restrictions adopted pursuant to paragraph 2 of this Article shall not apply to the use of a substance in scientific research and development as defined in Article 3, point (23), of Regulation (EC) No 1907/2006, carried out in relation to batteries.		P
4.	Where a restriction adopted pursuant to paragraph 2 of this Article does not apply to product and process orientated research and development, as defined in Article 3, point (22), of Regulation (EC) No 1907/2006, that exemption, as well as the maximum quantity of the substance exempted, shall be specified in Annex I to this Regulation.		N/A
5.	By 31 December 2027, the Commission, assisted by the European Chemicals Agency set up under Regulation (EC) No 1907/2006 ('the Agency'), shall prepare a report on substances of concern, namely substances having an adverse effect on human health or the environment or hampering recycling for safe and high quality secondary raw materials, present in batteries or used in their manufacture. The Commission shall submit that report to the European Parliament and to the Council detailing its findings and shall consider the appropriate follow-up measures including the adoption of delegated acts as referred to in paragraph 2 of this Article.		N/A
Article 7	Carbon footprint of electric vehicle batteries, rechargeable industrial batteries and LMT batteries	Not requested by client for this report, not mandatory until the specified date.	N/A

(EU) 2023/1542			
Clause	Requirement + Test	Result - Remark	Verdict
Article 8	Recycled content in industrial batteries, electric vehicle batteries, LMT batteries and SLI batteries	Not requested by client for this report, not mandatory until the specified date.	N/A
Article 9	Performance and durability requirements for portable batteries of general use	Not portable batteries of general use	N/A
1.	From 18 August 2028 or 24 months after the date of entry into force of the delegated act referred to in paragraph 2, whichever is the latest, portable batteries of general use, excluding button cells, shall meet the minimum values for the electrochemical performance and durability parameters set out in Annex III as laid down in the delegated act adopted pursuant to paragraph 2.		N/A
2.	By 18 August 2027, the Commission shall adopt a delegated act in accordance with Article 89 to supplement this Regulation by establishing mandatory minimum values for the electrochemical performance and durability parameters set out in Annex III for portable batteries of general use, excluding button cells.		N/A
	The Commission is empowered to adopt delegated acts in accordance with Article 89 to amend the minimum values referred to in the first subparagraph or add electrochemical performance and durability parameters to those set out in Annex III in view of technical and scientific progress.		N/A
	In preparing the delegated act referred to in the first subparagraph, the Commission shall consider the need to reduce the life cycle environmental impact of portable batteries of general use, including by means of increasing the resource efficiency thereof, and shall take into consideration relevant international standards and labelling schemes.		N/A
	The Commission shall also ensure that the provisions laid down by the delegated act referred to in the first subparagraph do not have a significant adverse impact on the safety and functionality of those batteries or the appliances, light means of transport or other vehicles into which those batteries are incorporated, the affordability and the cost for end-users and the industry's competitiveness.		N/A
3.	By 31 December 2030, the Commission shall assess the feasibility of measures to phase out non-rechargeable portable batteries of general use with a view to minimising their environmental impact based on the life cycle assessment methodology and viable alternatives for end-users. To that end, the Commission shall submit a report to the European Parliament and to the Council and consider taking the appropriate measures, including the adoption of legislative proposals for either the phase out or the setting of eco-design requirements.		N/A

(EU) 2023/1542			
Clause	Requirement + Test	Result - Remark	Verdict
Article 10	Performance and durability requirements for rechargeable industrial batteries, LMT batteries and electric vehicle batteries		P
1.	From 18 August 2024, rechargeable industrial batteries with a capacity greater than 2 kWh, LMT batteries and electric vehicle batteries shall be accompanied by a document containing values for the electrochemical performance and durability parameters set out in Part A of Annex IV.	Technical document include performance and durability requirements provided by manufacturer.	P
	For batteries referred to in the first subparagraph, the technical documentation referred to in Annex VIII shall contain an explanation of the technical specifications, standards and conditions used to measure, calculate or estimate the values for the electrochemical performance and durability parameters. That explanation shall include, at least, the elements set out in Part B of Annex IV.		P
2.	From either 18 August 2027 or 18 months after the date of entry into force of the delegated act referred to in the first subparagraph of paragraph 5, whichever is the latest, rechargeable industrial batteries with a capacity greater than 2 kWh, except those with exclusively external storage, shall meet the minimum values laid down in the delegated act adopted pursuant to the first subparagraph of paragraph 5 for the electrochemical performance and durability parameters set out in Part A of Annex IV.		N/A
3.	From either 18 August 2028 or 18 months after the date of entry into force of the delegated act referred to in the second subparagraph of paragraph 5, whichever is the latest, LMT batteries shall meet the minimum values laid down in the delegated act adopted pursuant to the second subparagraph of paragraph 5 for the electrochemical performance and durability parameters set out in Part A of Annex IV.		N/A
4.	Paragraphs 1, 2 and 3 shall not apply to a battery that has been subject to preparation for re-use, preparation for repurposing, repurposing or remanufacturing, where the economic operator placing that battery on the market or putting it into service demonstrates that the battery, before undergoing such operations, has been placed on the market or put into service before the dates on which those obligations become applicable in accordance with those paragraphs.		N/A
5.	By 18 February 2026, the Commission shall adopt a delegated act in accordance with Article 89 to supplement this Regulation by establishing minimum values for the electrochemical performance and durability parameters set out in Part A of Annex IV that rechargeable industrial batteries with a capacity greater than 2 kWh, except those with exclusively external storage, shall attain.		N/A

(EU) 2023/1542			
Clause	Requirement + Test	Result - Remark	Verdict
	By 18 February 2027, the Commission shall adopt a delegated act in accordance with Article 89 to supplement this Regulation by establishing minimum values for the electrochemical performance and durability parameters set out in Part A of Annex IV that LMT batteries shall attain.		N/A
	In preparing the delegated acts referred to in the first and second subparagraph, the Commission shall consider the need to reduce the life cycle environmental impact of rechargeable industrial batteries with a capacity greater than 2 kWh, except of those with exclusively external storage, and of LMT batteries, and ensure that the requirements laid down therein do not have a significant adverse impact on the functionality of those batteries or the appliances, light means of transport or other vehicles into which those batteries are incorporated, their affordability and industry's competitiveness.		N/A
6.	The Commission is empowered to adopt delegated acts in accordance with Article 89 to amend the electrochemical performance and durability parameters set out in Annex IV in light of market developments and technical and scientific progress, including, in particular, related to technical specifications of the informal UNECE Working Group on Electric Vehicles and the Environment.		N/A
Article 11	Removability and replaceability of portable batteries and LMT batteries	To be evaluated with end product.	N/A
Article 12	Safety of stationary battery energy storage systems	Not applicable to LMT batteries.	N/A
1.	Stationary battery energy storage systems placed on the market or put into service shall be safe during their normal operation and use.		N/A
2.	By 18 August 2024, the technical documentation referred to in Annex VIII shall:		N/A
	(a) demonstrate that the stationary battery energy storage systems are compliant with paragraph 1 and include evidence that they have been successfully tested for the safety parameters set out in Annex V, for which state-of-the-art testing methodologies shall be used. The safety parameters shall only apply in so far as a corresponding hazard exists for the stationary battery energy storage system in question when it is used under the conditions envisaged by the manufacturer;		N/A
	(b) include an assessment of possible safety hazards of the stationary battery energy storage system that are not addressed in Annex V;		N/A
	(c) include evidence that the hazards referred to in point (b) have been successfully mitigated and tested; state-of-the-art testing methodologies shall be used for such testing;		N/A
	(d) include mitigation instructions in case the identified hazards could occur, for example a fire or explosion.		N/A

(EU) 2023/1542			
Clause	Requirement + Test	Result - Remark	Verdict
	The technical documentation shall be reviewed if a battery is prepared for re-use, prepared for repurposing, remanufactured or repurposed.		N/A
3.	The Commission is empowered to adopt delegated acts in accordance with Article 89 to amend the safety parameters set out in Annex V in view of technical and scientific progress.		N/A
CHAPTER III	Labelling, marking and information requirements		P
Article 13	Labelling and marking of batteries		P
1.	From 18 August 2026 or 18 months after the date of entry into force of the implementing act referred to in paragraph 10, whichever is the latest, batteries shall bear a label containing the general information on batteries set out in Part A of Annex VI.	Not requested by client for this report, not mandatory until the specified date.	N/A
2.	From 18 August 2026 or 18 months after the date of entry into force of the implementing act referred to in paragraph 10, whichever is the latest, rechargeable portable batteries, LMT batteries and SLI batteries shall bear a label containing information on their capacity.		P
3.	From 18 August 2026 or 18 months after the date of entry into force of the implementing act referred to in paragraph 10, whichever is the latest, non-rechargeable portable batteries shall bear a label containing information on their minimum average duration when used in specific applications and a label indicating 'non-rechargeable'.		N/A
4.	From 18 August 2025, all batteries shall be marked with the symbol for separate collection of batteries ('separate collection symbol') as shown in Part B of Annex VI.	Separate collection symbol marked.	P
	The separate collection symbol shall cover at least 3 % of the area of the largest side of the battery up to a maximum size of 5 × 5 cm.		P
	In the case of cylindrical battery cells, the separate collection symbol shall cover at least 1,5 % of the surface area of the battery and shall have a maximum size of 5 × 5 cm.		N/A
	Where the size of the battery is such that the separate collection symbol would be smaller than 0,47 × 0,47 cm, the battery does not need to be marked with that symbol. Instead, a separate collection symbol measuring at least 1 × 1 cm shall be printed on the packaging.		N/A
5.	All batteries containing more than 0,002 % cadmium or more than 0,004 % lead, shall be marked with the chemical symbol for the metal concerned: Cd or Pb.		P
	The relevant chemical symbol indicating the heavy metal content shall be printed beneath the separate collection symbol and shall cover an area of at least one-quarter the size of that symbol.		P
6.	From 18 February 2027, all batteries shall be marked with a QR code as described in Part C of Annex VI. The QR code shall provide access to the following:	Not requested by client for this report, not mandatory until the specified date.	N/A

(EU) 2023/1542			
Clause	Requirement + Test	Result - Remark	Verdict
	(a) for LMT batteries, industrial batteries with a capacity greater than 2kWh and electric vehicles batteries, the battery passport in accordance with Article 77;		N/A
	(b) for other batteries, the applicable information referred to in paragraphs 1 to 5 of this Article, the declaration of conformity referred to in Article 18, the report referred to in Article 52(3) and the information regarding the prevention and management of waste batteries laid down in Article 74(1), points (a) to (f);		N/A
	(c) for SLI batteries, the amount of cobalt, lead, lithium or nickel recovered from waste and present in active materials in the battery, calculated in accordance with Article 8.		N/A
	This information shall be complete, up-to-date and accurate.		N/A
7.	The labels and the QR code referred to in paragraphs 1 to 6 shall be printed or engraved visibly, legibly and indelibly on the battery. Where this is not possible or not warranted on account of the nature and size of the battery, the labels and the QR code shall be affixed to the packaging and to the documents accompanying the battery.		N/A
8.	The Commission is empowered to adopt delegated acts in accordance with Article 89 to amend this Regulation to provide for alternative types of smart labels for use instead of or in addition to the QR code, in view of technical and scientific progress.		N/A
9.	Batteries that have been subject to preparation for re-use, preparation for repurposing, repurposing or remanufacturing shall bear new labels or shall be marked with markings in accordance with this Article, and containing information on their change of status in accordance with point 4 of Annex XIII, which shall be accessible through the QR code.		N/A
10.	The Commission shall, by 18 August 2025, adopt implementing acts to establish harmonised specifications for the labelling requirements referred to in paragraphs 1, 2 and 3 of this Article. Those implementing acts shall be adopted in accordance with the examination procedure referred to in Article 90(3).		N/A
Article 14	Information on the state of health and expected lifetime of batteries		P
1.	From 18 August 2024, up-to-date data for the parameters for determining the state of health and expected lifetime of batteries as set out in Annex VII shall be contained in the battery management system of stationary battery energy storage systems, LMT batteries and electric vehicle batteries.		P

(EU) 2023/1542			
Clause	Requirement + Test	Result - Remark	Verdict
2.	Read-only access to the data for the parameters set out in Annex VII through the battery management system referred to in paragraph 1 shall be provided, respecting the intellectual property rights of the battery manufacturer, on a non-discriminatory basis to the natural or legal person who has legally purchased the battery, including independent operators or waste management operators, or any third party acting on their behalf at any time, for the purpose of: (a) making the battery available to independent aggregators or market participants through energy storage; (b) evaluating the residual value or remaining lifetime of the battery and capability for further use, based on the estimation of the state of health of the battery; (c) facilitating the preparation for re-use, preparation for repurposing, repurposing or remanufacturing of the battery.	Read-only access to the data provided to purchaser by electronic version.	P
3.	The battery management system shall include a software reset function, in case economic operators carrying out preparation for re-use, preparation for repurposing, repurposing or remanufacturing need to upload different battery management system software. If the software reset function is used, the original battery manufacturer shall not be held liable for any breach of the safety or functionality of the battery that could be attributed to battery management system software uploaded after that battery was placed on the market.	Rest method provided by manufacturer, and instruction will be provided in the accompanied technical documentation.	P
4.	The Commission is empowered to adopt a delegated act in accordance with Article 89 to amend the parameters for determining the state of health and expected lifetime of batteries set out in Annex VII in view of market developments and technical and scientific progress and to ensure synergies with parameters set in UN Global Technical Regulation No 22 on in-vehicle battery durability for electrified vehicles, with due regard to the intellectual property rights of the battery manufacturer.		N/A
5.	The provisions of this Article shall apply in addition to those laid down in Union law on type approval of vehicles.		N/A
CHAPTER IV	Conformity of batteries		P
1.	The EU declaration of conformity shall state that the compliance with the requirements laid down in Articles 6 to 10 and Articles 12, 13 and 14 has been demonstrated.	Applicable article stated.	P

(EU) 2023/1542			
Clause	Requirement + Test	Result - Remark	Verdict
2.	The EU declaration of conformity shall have the model structure set out in Annex IX, shall contain the elements specified in the relevant modules set out in Annex VIII, and shall be kept up to date. It shall be translated into the language or languages required by the Member State in which the battery is placed or made available on the market or put into service. It shall be drawn up in electronic format and, where requested, it shall be provided in paper format.	EU DECLARATION OF CONFORMITY content provided.	P
3.	Where a battery is subject to more than one Union act requiring an EU declaration of conformity, a single EU declaration of conformity shall be drawn up in respect of all such Union acts. That declaration shall state the Union acts concerned and their publication references.		N/A
4.	By drawing up the EU declaration of conformity, the manufacturer shall assume responsibility for the compliance of the battery with the requirements laid down in this Regulation.		P
5.	Without prejudice to paragraph 3, a single EU declaration of conformity may be made up of one or more individual EU declarations of conformity already drawn up in compliance with a different Union act or acts, in order to reduce the administrative burden on economic operators.		N/A
Article 19	General principles of the CE marking		P
	The CE marking shall be subject to the general principles set out in Article 30 of Regulation (EC) No 765/2008.		P
Article 20	Rules and conditions for affixing the CE marking		P
1.	The CE marking shall be affixed visibly, legibly and indelibly to the battery. Where that is not possible or not warranted due to the nature of the battery, it shall be affixed to the packaging and to the documents accompanying the battery.		P
2.	The CE marking shall be affixed before the battery is placed on the market or put into service.		P
3.	The CE marking shall be followed by the identification number of the notified body where required under Annex VIII. That identification number shall be affixed by the notified body itself or, under its instructions, by the manufacturer or by its authorised representative.	Not mandatory now.	N/A
4.	The CE marking and the identification number referred to in paragraph 3 may be followed, if applicable, by any pictogram or other mark indicating a special risk, use or any danger linked to the use, storage, treatment or transport of the battery.		N/A
5.	Member States shall build upon existing mechanisms to ensure correct application of the regime governing the CE marking and shall take appropriate action in the event of improper use of that marking.		N/A
CHAPTER V	Notification of conformity assessment bodies		N/A
CHAPTER VI	Obligations of economic operators other than the obligations in Chapters VII and VIII		N/A

(EU) 2023/1542			
Clause	Requirement + Test	Result - Remark	Verdict
CHAPTER VII	Obligations of economic operators as regards battery due diligence policies	Not mandatory until the specified date.	N/A
Article 47	Scope of this Chapter		N/A
Article 48	Battery due diligence policies		N/A
1.	From 18 August 2025, economic operators that place batteries on the market or put them into service shall fulfil the due diligence obligations laid down in paragraphs 2 and 3 of this Article, and in Articles 49, 50 and 52 and shall, to that end, set up and implement battery due diligence policies.		N/A
2.	Economic operators referred to in paragraph 1 of this Article shall have their battery due diligence policies verified by a notified body in accordance with Article 51 ('third-party verification') and periodically audited by that notified body to make sure that the battery due diligence policies are maintained and applied in accordance with Articles 49, 50 and 52. The notified body shall provide the audited economic operator with an audit report.		N/A
3.	Economic operators referred to in paragraph 1 of this Article shall keep documentation demonstrating their fulfilment of the obligations laid down in Articles 49, 50 and 52, including the verification report and approval decision referred to in Article 51 and the audit reports referred to in paragraph 2 of this Article, for 10 years after the last battery manufactured under the relevant battery due diligence policy has been placed on the market.		N/A
4.	Without prejudice to the individual responsibility of economic operators for their battery due diligence policies, economic operators referred to in paragraph 1 of this Article may, for the purposes of compliance with the requirements laid down in Articles 48, 49, 50 and 52, collaborate with other actors, including through due diligence schemes recognised under this Regulation.		N/A
5.	By 18 February 2025, the Commission shall publish guidelines as regards the application of the due diligence requirements laid down in Articles 49 and 50, with regard to the risks referred to in point 2 of Annex X, and in line, in particular, with the international instruments referred to in points 3 and 4 of Annex X.		N/A
6.	Member States may, in order to provide information and support to economic operators in fulfilling the due diligence obligations under this Regulation, set up and operate, individually or jointly, dedicated websites, platforms or portals.		N/A
7.	The Commission may complement the Member State support measures referred to in paragraph 6, by building on existing Union action to support due diligence in the Union and in third countries, and may devise new measures to help economic operators fulfil their obligations under this Regulation.		N/A

(EU) 2023/1542			
Clause	Requirement + Test	Result - Remark	Verdict
8.	<p>The Commission shall regularly assess the need to update the list of raw materials and risk categories set out in Annex X.</p> <p>The Commission is empowered to adopt delegated acts in accordance with Article 89 to:</p> <p>(a) amend the list of raw materials in point 1 of Annex X and of risk categories in point 2 of Annex X, in view of scientific and technological progress in battery manufacturing and chemistries and amendments to Regulation (EU) 2017/821;</p> <p>(b) amend the list of international instruments in point 3 of Annex X, in accordance with developments within the relevant international fora concerning standards related to due diligence policies and to protection of the environment and of social rights;</p> <p>(c) amend the obligations on the economic operators referred to in paragraph 1 of this Article which are laid down in Articles 49 and 50 in view of amendments to Regulation (EU) 2017/821, and amend the list of internationally recognised due diligence instruments set out in point 4 of Annex X.</p>		N/A
Article 49	Economic operator's management system		N/A
1.	Each economic operator referred to in Article 48(1) shall:		N/A
	(a) adopt, and clearly communicate to suppliers and the public, a company battery due diligence policy, concerning raw materials listed in point 1 of Annex X, and associated social and environmental risk categories listed in point 2 of Annex X;		N/A
	(b) incorporate in its battery due diligence policy standards that are consistent with the standards set out in the internationally recognised due diligence instruments listed in point 4 of Annex X;		N/A
	(c) structure its internal management system to support its battery due diligence policy by assigning responsibility to its top management level to oversee its battery due diligence policy as well as maintain records of that system for a minimum of 10 years;		N/A
	(d) establish and operate a system of controls and transparency regarding the supply chain, including a chain of custody or traceability system, identifying upstream actors in the supply chain;		N/A
	(e) incorporate its battery due diligence policy, including risk management measures, into contracts and agreements with suppliers; and		N/A
	(f) establish a grievance mechanism, including an early-warning risk-awareness system and a remediation mechanism, or provide for such mechanisms through collaborative agreements with other economic operators or organisations or by facilitating recourse to an external expert or body, such as an ombudsman; such mechanisms shall be based on the UN Guiding Principles on Business and Human Rights.		N/A

(EU) 2023/1542			
Clause	Requirement + Test	Result - Remark	Verdict
2.	The system referred to in paragraph 1, point (d), shall be supported by documentation that provides at least the following information:		N/A
	(a) a description of the raw material, including its trade name and type;		N/A
	(b) the name and address of the supplier that supplied the raw material present in the batteries to the economic operator that places the batteries containing the raw material in question on the market;		N/A
	(c) the country of origin of the raw material and the market transactions from the raw material's extraction to the immediate supplier to the economic operator that places the battery on the market;		N/A
	(d) the quantities of the raw material present in the battery placed on the market, expressed in percentage or weight;		N/A
	(e) third-party verification reports issued by a notified body and concerning the suppliers as referred to in Article 50(3);		N/A
	(f) if the reports referred to in point (e) are not available and where the raw material originates from a conflict-affected and high-risk area, additional information in accordance with the specific recommendations for upstream economic operators, as set out in the OECD Due diligence guidance for Responsible Supply Chains of Minerals from Conflict- Affected and High-Risk Areas, where relevant, such as the mine of origin, locations where the raw material is consolidated, traded and processed, and taxes, fees and royalties are paid.		N/A
	Third party verification reports referred to in point (e) of the first subparagraph shall be made available by suppliers as referred to in Article 50(3) to the downstream operators of the supply chain.		N/A
Article 50	Risk management obligations		N/A
1.	The economic operator referred to in Article 48(1) shall:		N/A
	(a) identify and assess the risk of adverse impacts in its supply chain, associated with the risk categories listed in point 2 of Annex X as part of its management plan, including on the basis of the information provided pursuant to Article 49 and any other relevant information that is either publicly available or provided by stakeholders, by reference to its battery due diligence policy;		N/A

(EU) 2023/1542			
Clause	Requirement + Test	Result - Remark	Verdict
	<p>(b) design and implement a strategy to respond to the identified risks to prevent, mitigate and otherwise address adverse impacts by:</p> <p>(i) reporting findings of its risk assessment to its top management level assigned in accordance with Article 49(1), point (c);</p> <p>(ii) adopting risk management measures that are consistent with the internationally recognised due diligence instruments listed in point 4 of Annex X, considering its ability to influence, and where necessary take steps to exert pressure on, suppliers, including their subsidiaries and subcontractors, who can most effectively prevent or mitigate the identified risk;</p> <p>(iii) designing and implementing a risk management plan, monitoring and tracking performance of risk mitigation efforts, reporting back to its top management level assigned in accordance with Article 49(1), point (c), and considering suspending or discontinuing engagement with a supplier or its subsidiary or subcontractor after failed attempts at mitigation, based on relevant contracts and agreements referred to in Article 49(1), point (e);</p> <p>(iv) undertaking additional fact and risk assessments for risks requiring mitigation, or after a change of circumstances.</p>		N/A
2.	<p>If the economic operator referred to in Article 48(1) pursues risk mitigation efforts while continuing trade or temporarily suspending trade, it shall consult with suppliers and with the stakeholders concerned, including local and national government authorities, international or civil society organisations and affected third parties such as local communities, before establishing a strategy for measurable risk mitigation in the risk management plan referred to in paragraph 1, point (b)(iii), of this Article.</p>		N/A
3.	<p>The economic operator referred to in Article 48(1) shall identify and assess the probability of adverse impacts in the risk categories listed in point 2 of Annex X, in its supply chain. That economic operator shall identify and assess the risks in its supply chain as part of its own risk management systems. The economic operator shall carry out third party verifications of its own due diligence chains via a notified body in accordance with Article 51. The economic operator may use third-party verification reports issued pursuant to Article 51(2) by such a notified body concerning battery due diligence policies implemented by suppliers in that chain in accordance with this Chapter. The economic operator may also use those third-party verification reports to assess, as appropriate, the due diligence practices of those suppliers.</p>		N/A

(EU) 2023/1542			
Clause	Requirement + Test	Result - Remark	Verdict
4.	The economic operator referred to in Article 48(1) shall report the findings of the risk assessment referred to in paragraph 3 of this Article to its top management level to which responsibility has been assigned in accordance with Article 49(1), point (c), and shall implement the strategy referred to in paragraph 1, point (b), of this Article.		N/A
Article 51	Third-party verification of battery due diligence policies		N/A
Article 52	Disclosure of information on battery due diligence policies		N/A
1.	The economic operator referred to in Article 48(1) shall make available upon request to Member States' market surveillance authorities or national authorities the verification report and approval decision issued in accordance with Article 51, the audit reports referred to in Article 48(2) and available evidence of compliance with a due diligence scheme recognised by the Commission in accordance with Article 53.		N/A
2.	The economic operator referred to in Article 48(1) shall make available to its immediate downstream purchasers all relevant information gained and maintained pursuant to its battery due diligence policy, with due regard for business confidentiality and other competitive concerns.		N/A
3.	The economic operator referred to in Article 48(1) shall on an annual basis review and make publicly available, including on the internet, a report on its battery due diligence policy. That report shall contain, in a manner that is easily comprehensible for end-users and clearly identifies the batteries concerned, the data and information on steps taken by that economic operator to comply with the requirements laid down in Articles 49 and 50, including findings of significant adverse impacts in the risk categories listed in point 2 of Annex X, and how they have been addressed, as well as a summary report of the third-party verifications carried out in accordance with Article 51, including the name of the notified body, with due regard for business confidentiality and other competitive concerns. That report shall also cover, where relevant, access to information, public participation in decision-making and access to justice in environmental matters in relation to the sourcing, processing and trading of the raw materials present in batteries.		N/A
4.	Where the economic operator referred to in Article 48(1) can demonstrate that the raw materials listed in point 1 of Annex X, that are present in the battery are derived from recycled sources, it shall publicly disclose its conclusions in reasonable detail, with due regard for business confidentiality and other competitive concerns.		N/A
Article 53	Recognition of due diligence schemes		N/A

(EU) 2023/1542			
Clause	Requirement + Test	Result - Remark	Verdict
CHAPTER VIII	Management of waste batteries		N/A
CHAPTER IX	Digital battery passport	Not mandatory now.	N/A
Article 77	Battery passport		N/A
1.	From 18 February 2027 each LMT battery, each industrial battery with a capacity greater than 2 kWh and each electric vehicle battery placed on the market or put into service shall have an electronic record ('battery passport').		N/A
2.	The battery passport shall contain information relating to the battery model and information specific to the individual battery, including resulting from the use of that battery, as set out in Annex XIII.1.		N/A
	The information in the battery passport shall comprise: (a) information accessible to the general public in accordance with point 1 of Annex XIII; (b) information accessible only to notified bodies, market surveillance authorities and the Commission in accordance with points 2 and 3 of Annex XIII; and (c) information accessible only to any natural or legal person with a legitimate interest in accessing and processing that information for the purposes referred to in points (a) and (b) of the third subparagraph in accordance with points 2 and 4 of Annex XIII.		N/A
	The purposes for accessing and processing the information as referred to in point (c) of the second subparagraph, shall: (a) concern dismantling of the battery, including safety measures to be taken during the dismantling, and the detailed composition of the battery model and be essential to allow repairers, remanufacturers, second-life operators and recyclers to conduct their respective economic activities in accordance with this Regulation; (b) in the case of individual batteries, be essential to the purchaser's behalf, for the purpose of making the individual battery available to independent energy aggregators or energy market participants.		N/A
	The information referred to in the second subparagraph shall be included in the battery passport to the extent applicable to the category or sub-category of battery concerned.		N/A
	The Commission is empowered to adopt delegated acts in accordance with Article 89 to amend Annex XIII as regards the information to be included in the battery passport in view of technical and scientific progress.		N/A
3.	The battery passport shall be accessible through the QR code referred to in Article 13(6) which links to a unique identifier that the economic operator placing the battery on the market shall attribute to it.		N/A

(EU) 2023/1542			
Clause	Requirement + Test	Result - Remark	Verdict
	The QR code and the unique identifier shall comply with the ISO/IEC standards 15459-1:2014, 15459-2:2015, 15459-3:2014, 15459-4:2014, 15459-5:2014 and 15459-6:2014 or their equivalent.		N/A
	The Commission is empowered to adopt delegated acts in accordance with Article 89 to amend the second subparagraph of this paragraph in light of technical and scientific progress by replacing the standards referred to in that subparagraph or adding other European or international standards with which the QR code and the unique identifier shall comply.		N/A
4.	The economic operator placing the battery on the market shall ensure that the information in the battery passport is accurate, complete and up to date. It may give written authorisation to any other operator to act on its behalf.		N/A
5.	All information included in the battery passport shall be based on open standards and be in an interoperable format, transferable through an open interoperable data exchange network without vendor lock-in, machine-readable, structured and searchable, in accordance with the essential requirements laid down in Article 78.		N/A
6.	The access to information included in the battery passport shall be regulated in accordance with the essential requirements laid down in Article 78.		N/A
7.	For a battery that has been subject to preparation for re-use, preparation for repurposing, repurposing or remanufacturing, the responsibility for the fulfilment of the obligations under paragraph 4 of this Article shall be transferred to the economic operator that has placed that battery on the market or has put it into service. Such battery shall have a new battery passport linked to the battery passport or passports of the original battery or batteries.		N/A
	Where the status of a battery changes to that of a waste battery, the responsibility for the fulfilment of the obligations under paragraph 4 of this Article shall be transferred either to the producer or, where appointed in accordance with Article 57(1), the producer responsibility organisation, or the waste management operator selected in accordance with Article 57(8).		N/A
8.	A battery passport shall cease to exist after the battery has been recycled.		N/A
9.	By 18 August 2026, the Commission shall adopt implementing acts specifying which persons are to be considered persons with a legitimate interest as referred to in points 2 and 4 respectively of Annex XIII for the purposes of paragraph 2, point (c), of this Article and to which information listed in those points they shall have access, and to what extent they can download, share, publish and re-use that information. Those implementing acts shall be adopted in accordance with the examination procedure referred to in Article 90(3).		N/A

(EU) 2023/1542			
Clause	Requirement + Test	Result - Remark	Verdict
	The criteria for specifying the persons referred to in paragraph 2, point (c), and for determining the extent to which they can download, share, publish and re-use the information referred to in points 2 and 4 of Annex XIII shall be the following: (a) the necessity of having such information in order to evaluate the status and residual value of the battery and its capability for further use; (b) the necessity of having such information for the purpose of preparation for re-use, preparation for repurposing, repurposing, remanufacturing or recycling of the battery, or for choosing between those operations; (c) the need to ensure that the accessing and processing of information in the battery passport that is commercially sensitive is limited to the minimum necessary in accordance with applicable Union law.		N/A
Article 78	Technical design and operation of the battery passport		N/A
	The technical design and operation of the battery passport shall comply with the following essential requirements:		N/A
	(a) the battery passport shall be fully interoperable with other digital product passports required by Union law concerning eco-design, in relation to the technical, semantic and organisational aspects of end-to-end communication and data transfer;		N/A
	(b) consumers, economic operators and other relevant actors shall have access to the battery passport free of charge and based on their respective access rights set out in Annex XIII and the implementing act adopted pursuant to Article 77(9);		N/A
	(c) the data included in the battery passport shall be stored by the economic operator responsible for the fulfilment of the obligations under Article 77(4) or (7), or by operators authorised to act on their behalf;		N/A
	(d) if the data included in the battery passport are stored or otherwise processed by operators authorised to act on behalf of the economic operator responsible for the fulfilment of the obligations under Article 77(4) or (7), those operators shall not be allowed to sell, re-use or process such data, in whole or in part, beyond what is necessary for the provision of the relevant storing or processing services;		N/A
	(e) the battery passport shall remain available after the economic operator responsible for the fulfilment of the obligations under Article 77(4) or (7) ceases to exist or ceases its activity in the Union;		N/A
	(f) the rights to access, introduce, modify or update information in the battery passport shall be restricted based on the access rights specified in Annex XIII and the implementing act adopted pursuant to Article 77(9);		N/A

(EU) 2023/1542			
Clause	Requirement + Test	Result - Remark	Verdict
	(g) data authentication, reliability and integrity shall be ensured;		N/A
	(h) the battery passport shall be such that a high level of security and privacy is ensured and fraud is avoided.		N/A
CHAPTER X	Union market surveillance and Union safeguard procedures		N/A
CHAPTER XI	Green public procurement and procedure for amending restrictions on substances		N/A
CHAPTER XII	Delegated powers and committee procedure		N/A
CHAPTER XIII	Amendments		N/A
CHAPTER XIV	Final provisions		N/A
ANNEX I	RESTRICTION ON SUBSTANCES		P
ANNEX II	CARBON FOOTPRINT		N/A
ANNEX III	ELECTROCHEMICAL PERFORMANCE AND DURABILITY PARAMETERS FOR PORTABLE BATTERIES OF GENERAL USE		N/A
ANNEX IV	ELECTROCHEMICAL PERFORMANCE AND DURABILITY REQUIREMENTS FOR LMT BATTERIES, INDUSTRIAL BATTERIES WITH A CAPACITY GREATER THAN 2 KWH AND ELECTRIC VEHICLE BATTERIES		N/A
ANNEX V	SAFETY PARAMETERS		N/A
ANNEX VI	LABELLING, MARKING AND INFORMATION REQUIREMENTS	See Article 13, for separate collection symbol and capacity marking only.	P
ANNEX VII	PARAMETERS FOR DETERMINING THE STATE OF HEALTH AND EXPECTED LIFETIME OF BATTERIES		N/A
ANNEX VIII	CONFORMITY ASSESSMENT PROCEDURES		P
ANNEX IX	EU DECLARATION OF CONFORMITY No* ... * (identification number of the declaration)	EU DECLARATION OF CONFORMITY content provided.	P
ANNEX X	LIST OF RAW MATERIALS AND RISK CATEGORIES		N/A
ANNEX XI	CALCULATION OF COLLECTION RATES FOR WASTE PORTABLE BATTERIES AND WASTE LMT BATTERIES		N/A
ANNEX XII	STORAGE AND TREATMENT, INCLUDING RECYCLING, REQUIREMENTS		N/A
ANNEX XIII	INFORMATION TO BE INCLUDED IN THE BATTERY PASSPORT		N/A

(EU) 2023/1542			
Clause	Requirement + Test	Result - Remark	Verdict
ANNEX XIV	MINIMUM REQUIREMENTS FOR SHIPMENTS OF USED BATTERIES		N/A
ANNEX XV	CORRELATION TABLE		N/A

(EU) 2023/1542			
Clause	Requirement + Test	Result - Remark	Verdict

TABLE: Critical components information					
Object / part No.	Manufacturer/ trademark	Type / model	Technical data	Standard	Mark(s) of conformity
PCB	SHENZHEN UNIWELL CIRCUITS CO LTD	UW01	130°C, V-0	UL 94 UL 796	UL E314500
IC (U1)	ABLIC Inc.	S-1142B33I-E6T1U	V _{IN} : 3.0V to 50V, V _{OUT} : 3.3 V±1.0%, T _{opr} : -40°C to 85°C	--	Tested with appliance
IC (U3)	ABLIC Inc.	S-1142B50I-E6T1U	V _{IN} : 3.0V to 50V, V _{OUT} : 5V±1.0%, T _{opr} : -40°C to 85°C	--	Tested with appliance
IC (U4)	3PEAK INCORPORATED	TPV6823S-TR	V _{CC} : -0.3V to 6V, Output Current: 20mA, T _A : -40°C to 125°C	--	Tested with appliance
IC (U5)	Nations Technologies Inc	N32L406CBL7	V _{IN} : 1.8V to 3.6V, T _A : -40°C to 105°C	--	Tested with appliance
IC (U6)	Texas Instruments Incorporated	BQ7694202PFB	V _{BAT} : 4.7V to 55V, T _A : -40°C to 85°C	--	Tested with appliance
IC (U9)	Texas Instruments Incorporated	TLV2379IDR	V _{IN} : 1.8V to 5.5V, T _A : -40°C to 125°C	--	Tested with appliance
MOSFET (Q7, Q8, Q9, Q10, Q11, Q12)	Wuxi NCE Power Semiconductor Co., Ltd	NCEP040N85G	V _{DS} : 85V, V _{GS} : ±20V, I _D : 130A, T _{STG} : -55°C to 150°C	--	Tested with appliance
MOSFET (Q19)	Wuxi NCE Power Semiconductor Co., Ltd	NCE0103M	V _{DS} : 100V, V _{GS} : ±20V, I _D : 3A, T _{STG} : -55°C to 150°C	--	Tested with appliance
PTC (F1, F3, F4)	FUZETEC TECHNOLOGY CO LTD	FSMD016-1206-R	V _r : 48V, V _{max} : 48V, I _h : 160mA, I _t : 450, I _{max} : 100 I _{sc} : 100, T _{moa} : 85°C	UL 1434 EN 60738-1:1999 EN 60738-1-1:1999	UL E211981 TÜV R 50090556
FUSE (F2)	Wayon Electronics co., Ltd	WPF30A14K	Operation Current: 30A, Maximum Voltage: 80V	UL 248-1 UL 248-14	UL E311435
NTC (R11)	CHENZHOU AMPRON Sensing TechnologyCo., Ltd	WPF30A14K_30A/80VDC	R ₂₅ : 10KΩ±1%, B _{25/85} : 3435K±1%, -40°C to 150°C	--	--

(EU) 2023/1542					
Clause	Requirement + Test			Result - Remark	Verdict
Cell	LG ENERGY SOLUTION, LTD.	INR21700M50L T	3.69Vdc, 4800mAh	IEC 62133-2:2017	CB Certificate No.: DK-112813-UL, DK-112813-M1-UL and DK-112813-M2-UL
Plastic cell support	KINGFA SCI & TECH CO LTD	JH960 HT (M1) (sr)	PC+ABS, V-0, thickness, 1.5mm	UL 94 UL 746	UL E171666
Wire (discharge)	DONGGUAN ZHONGZHEN NEW ENERGY TECHNOLOGY CO.,LTD	3135	16AWG, 200°C, 600Vac	UL 758	UL E355578
Connector (Charge & discharge)	Changzhou Amass Electronics Co Ltd	XT30U-M	500V, 15A, PA66	UL 1977	UL E482722
Plastic enclosure	KINGFA SCI & TECH CO LTD	JH98 (dd)-HT(M1) (ddd) (##) (f1)	PC+ABS, V-0, Min. thickness: 1.5mm, 100°C	UL 94 UL 746	UL E171666
Metal Enclosure	Kunshan Mingjie Hardware Electronics Co.,Ltd.	TB01	6063-T5, 2.0mm	--	--

--End of Main Report--

Report No.: 168497397c 001

Page 1 of 33

Client: SHENZHEN TOPBAND CO., LTD.

Contact Information: 1st Floor, Phase II, Topband Industrial, Park, Keji 2nd Road, Tangtou Community, Shiyan Street, Bao'an District, Shenzhen City, Guangdong, P.R. China

Test item(s): 50 materials

**Identification/
Model No(s):** Rechargeable Li-ion Battery pack
E36100B-ST1

Sample obtaining method: Sending by customer

Condition at delivery: Test item complete and undamaged.

Sample Receiving date: 2024-09-23

Testing Period: 2024-09-24 - 2024-10-21

Place of testing: Chemical laboratory Shenzhen

Test Specification:

Please refer to "Test Result Summary List" on page 2 for details

For and on behalf of
TÜV Rheinland (Shenzhen) Co., Ltd.



2024-12-09

Mike Huang / Engineer

Date

Name/Position

Sample information is provided by customer. Test result is drawn according to the kind and extent of tests performed.
This test report relates to the above mentioned test sample. Without permission of the test center this test report is not permitted to be duplicated in extracts. This test report does not entitle to carry any safety mark on this or similar products.
"Decision Rule" document announced in our website (<https://www.tuv.com/landingpage/en/qm-gcn/>) describes the statement of conformity and its rule of enforcement for test results are applicable throughout this test report.

Test Result Summary :

<i>Test Specification:</i>	<i>Test result:</i>
1 Heavy Metal Test for Battery - according to Annex I of Regulation (EU) 2023/1542	PASS
2 Total Cadmium Content in accordance to: REACH regulation (EC) No. 1907/2006 Annex XVII Item 23 and its amendments (EC) No. 552/2009, (EU) No. 494/2011 and (EU) No. 835/2012 and (EU) No.217/2016.	PASS
3 Selected Perfluorinated carboxylic acids (C9-C14 PFCAs) and related substances	PASS
4 Organotin compounds content according to REACH Regulation (EC) No. 1907/2006 Annex XVII Item 20 and amendment Commission Regulation (EU) No. 276/2010 (formerly known as 2009/425/EC)	PASS
5 Octabromodiphenylether (OctaBDE) content accordance to: REACH regulation (EC) No. 1907/2006 Annex XVII entry 45	PASS
6 REACH regulation (EC) No. 1907/2006 and its amendment regulations on Annex XVII entry 51: Phthalates	PASS
7 Dimethyl fumarate Content - According to REACH regulation (EC) No. 1907/2006 Annex XVII Entry 61 and its amendments	PASS
8 Polycyclic aromatic hydrocarbons (PAHs) - REACH regulation (EC) No. 1907/2006 with Amendment No. 552/2009- Annex XVII Item No. 50 and (EU) No.1272/2013	PASS
9 REACH regulation (EC) No. 1907/2006 and amendment no. 552/2009 Annex XVII entries 62: Phenylmercury compounds	PASS
10 REACH Regulation (EC) No. 1907/2006, the last amendment (EU) 2015/628 entry 63 of Annex XVII - Total Lead Content	PASS

Test Report No.: 168497397c 001

Page 3 of 33

Material List:

Item: Rechargeable Li-ion Battery pack
E36100B-ST1

Material No.	Material	Color	Location
M111	Plastic	red	Refer to photo
M112	Plastic	dark green	Refer to photo
M113	Plastic + printing + adhesive	multicolor	Refer to photo
M114	Plastic + printing + adhesive	multicolor	Refer to photo
M115	Plastic + printing + adhesive	black/white	Refer to photo
M116	Plastic	black	Refer to photo
M117	Plastic	black	Refer to photo
M118	Glue	black	Refer to photo
M119	Plastic	black	Refer to photo
M120	Glue	beige	Refer to photo
M121	PCB board	green	Refer to photo
M122	Plastic	transparent	Refer to photo
M123	Plastic	red	Refer to photo
M124	Plastic	black	Refer to photo
M125	Plastic	white	Refer to photo
M126	Plastic	black	Refer to photo
M127	PCB board	green	Refer to photo
M128	Glue	white	Refer to photo
M129	PCB board	green	Refer to photo
M130	Plastic	red	Refer to photo
M131	Plastic	black	Refer to photo
M132	Plastic	black	Refer to photo
M133	Plastic	yellow	Refer to photo
M134	Plastic	red	Refer to photo
M135	Plastic	black	Refer to photo
M136	Plastic	black	Refer to photo

Test Report No.: 168497397c 001

Page 4 of 33

M137	Plastic	red	Refer to photo
M138	Plastic	yellow	Refer to photo
M139	Plastic	red	Refer to photo
M140	Plastic	green	Refer to photo
M141	Plastic	black	Refer to photo
M142	Plastic	red	Refer to photo
M143	Plastic	green	Refer to photo
M144	Plastic	light yellow	Refer to photo
M145	Plastic	black	Refer to photo
M146	Textile + adhesive	black	Refer to photo
M147	Plastic + adhesive	yellow	Refer to photo
M148	Foam + coating	black	Refer to photo
M157	Plastic	red	Refer to photo
M158	Plastic	black	Refer to photo
M159	Plastic	black	Refer to photo
M160	Battery	multi color	Refer to photo
M161	Plastic + printing	grey/black	Refer to photo
M162	Plastic	white	Refer to photo
M163	Paper	white	Refer to photo
M164	Plastic	dark blue	Refer to photo
M165	Plastic	white	Refer to photo
M166	Component(s)	dark brown	Refer to photo
M167	Plastic	white	Refer to photo
M168	Component(s)	dark grey	Refer to photo

1. Heavy Metal Test for Battery - according to Annex I of Regulation (EU) 2023/1542

Test Method: Acid digestion, analyzed by ICP-OES/AAS

Test result

Test No.	Material No.	Test Parameter	Unit	RL	Regulatory requirement		Test Result
					Maximum Permissible Limit	Labelling Limit	
T012	M160	Cadmium	%	0.001	Portable batteries: 0.002	0.002	< RL
		Lead	%	0.001	Portable batteries: 0.01#	0.004	0.003
		Mercury	%	0.0005	0.0005	n.a.	< RL

Abbreviation: Pb = Lead
 Cd = Cadmium
 Hg = Mercury
 n.a.= not applicable
 RL = Reporting Limit
 < = Less than

Remark:

- # According to Article 6(1) and Annex I of the Regulation (EU) 2023/1542, the Lead restriction shall apply to portable batteries and portable zinc-air button cells from 18 August 2024 and 18 August 2028 respectively.
- * According to Article 13(4) and 13(5) of the Regulation (EU) 2023/1542, all batteries shall be marked with the symbol indicating 'separate collection'; and all batteries containing more than 0.002% cadmium or more than 0.004% lead shall be marked with the chemical symbol for the metal concerned.

2.Total Cadmium Content

Test Method: Acid digestion, analyzed by AAS/ ICP-OES

Test Result:

Test No.	Material No.	Test Parameter	Unit	RL	Regulatory Requirement	Test Result
T033	M111 + M112 + M113	Cadmium	mg/kg	10	100	< RL
T034	M114 + M115 + M116	Cadmium	mg/kg	10	100	< RL
T035	M117 + M118 + M119	Cadmium	mg/kg	10	100	< RL
T036	M120 + M122 + M123	Cadmium	mg/kg	10	100	< RL
T037	M121 + M127 + M129	Cadmium	mg/kg	10	100	< RL
T038	M124 + M125 + M126	Cadmium	mg/kg	10	100	< RL
T039	M128 + M130 + M131	Cadmium	mg/kg	10	100	< RL
T040	M132 + M133 + M134	Cadmium	mg/kg	10	100	< RL

Test Report No.: 168497397c 001

Page 7 of 33

Test No.	Material No.	Test Parameter	Unit	RL	Regulatory Requirement	Test Result
T041	M135 + M136 + M137	Cadmium	mg/kg	10	100	< RL
T042	M138 + M139 + M140	Cadmium	mg/kg	10	100	< RL
T043	M141 + M142 + M143	Cadmium	mg/kg	10	100	< RL
T044	M144 + M145	Cadmium	mg/kg	10	100	< RL
T045	M146 + M147 + M148	Cadmium	mg/kg	10	100	< RL
T046	M161 + M162 + M164	Cadmium	mg/kg	10	100	< RL
T047	M163 + M165 + M167	Cadmium	mg/kg	10	100	< RL
T048	M157 + M158 + M159	Cadmium	mg/kg	10	100	< RL

Abbreviation: < = less than
 RL = Reporting Limit
 mg/kg = milligram per kilogram

Test Report No.: 168497397c 001 Page 8 of 33

Remark:

* Regulations on Cadmium

EU	Legislation	Maximum Permissible Limit				
		Plastic materials	Paint (wet state)	Paint on the painted articles	Paint (high zinc content)	Metal parts of jewellery and imitation jewellery articles and hair assessories
EC	REACH regulation (EC) No. 1907/2006 Annex XVII Item 23 and its amendments (EC) No. 552/2009, (EU) No. 494/2011, (EU) No. 835/2012 and (EU) No. 217/2016.	100mg/kg	100mg/kg	1000mg/kg	1000mg/kg	100mg/kg

Country	Legislation	Maximum Permissible Limit	
		Paint, plastic, plating/ coating of surface treatment	Paint (high zinc content)
Switzerland	Switzerland Chemikalien-Risikoreduktions-Verordnung-ChemRRV, 814.81, 18 May 2005	100mg/kg	-

3. Selected Perfluorinated carboxylic acids (C9-C14 PFCAs) and related substances

Test Method: In house method, determination by CI-GCMS, GC-MSMS and LC-MSMS

Test Parameter	CAS NO	Unit	RL	Regulatory Requirement	Test No.	T018	T019
					Material No.	M111 + M112 + M113	M115 + M116 + M117
Test Parameter	CAS NO	Unit	RL	Regulatory Requirement	Result	Result	Result
Perfluorononan-1-oic acid (PFNA)	375-95-1	mg/kg	0.01	-	< RL	< RL	< RL
Perfluorodecanoic acid (PFDA)	335-76-2	mg/kg	0.01	-	< RL	< RL	< RL
Perfluoroundecanoic acid (PFUnA)	2058-94-8	mg/kg	0.01	-	< RL	< RL	< RL
Perfluorododecanoic acid (PFDoA)	307-55-1	mg/kg	0.01	-	< RL	< RL	< RL
Perfluorotridecanoic acid (PFTrA)	72629-94-8	mg/kg	0.01	-	< RL	< RL	< RL
Perfluorotetradecanoic acid (PFTeA)	376-06-7	mg/kg	0.01	-	< RL	< RL	< RL
Perfluoro-3,7-dimethyloctanoic acid (PF-3,7-DMOA)	172155-07-6	mg/kg	0.01	-	< RL	< RL	< RL
Sum of C9-C14 PFCAs	--	mg/kg	--	0.025	<RL	<RL	<RL
1H,1H,2H,2H-Perfluoro-1-decanol (8:2 FTOH)	678-39-7	mg/kg	0.25	-	< RL	< RL	< RL
1H,1H,2H,2H-Perfluoro-1-dodecanol (10:2 FTOH)	865-86-1	mg/kg	0.25	-	< RL	< RL	< RL
Perfluorodecanesulfonate (PFDS)	335-77-3	mg/kg	0.01	-	< RL	< RL	< RL
2H,2H,3H,3H-Perfluoroundecanoic acid (H4PFUnA)	34598-33-9	mg/kg	0.01	-	< RL	< RL	< RL
1H,1H,2H,2H-Perfluorododecanesulfonic acid (10:2 FTS)	120226-60-0	mg/kg	0.1	-	< RL	< RL	< RL
1H,1H,2H,2H-Perfluorododecanesulfonic acid (8:2-FTSA)	39108-34-4	mg/kg	0.1	-	< RL	< RL	< RL
1H,1H,2H,2H-perfluorotetradecan-1-ol (12:2 FTOH)	39239-77-5	mg/kg	0.1	-	< RL	< RL	< RL
1H,1H,2H,2H-Perfluorododecylacrylate (10:2 FTA)	17741-60-5	mg/kg	0.1	-	< RL	< RL	< RL
1H, 1H, 2H, 2H-Perfluorodecylchloromethylsilane (C8-PFSi)	3102-79-2	mg/kg	0.1	-	< RL	< RL	< RL
8:2 Fluorotelomer olefin (8:2 FTO)	21652-58-4	mg/kg	0.1	-	< RL	< RL	< RL
1H,1H,2H,2H-Perfluorodecyl acrylate (8:2-FTA)	27905-45-9	mg/kg	0.1	-	< RL	< RL	< RL
Perfluorooctylethyl Methacrylate (8:2-FTMAC)	1996-88-9	mg/kg	0.1	-	< RL	< RL	< RL
1H,1H,2H,2H-Heptadecafluoro-1-iododecane (8:2-FTI)	2043-53-0	mg/kg	0.1	-	< RL	< RL	< RL
2-(Perfluorodecyl)ethyl methacrylate (10:2 FTMA)	2144-54-9	mg/kg	0.1	-	< RL	< RL	< RL
1H,1H,2H,2H-Perfluorododecyl iodide (10:2 FTI)	2043-54-1	mg/kg	0.1	-	< RL	< RL	< RL
1H,1H,2H,2H-Perfluorotetradecyl iodide (12:2 FTI)	30046-31-2	mg/kg	0.1	-	< RL	< RL	< RL
Sum of C9-C14 PFCA related substances	--	mg/kg	--	0.26	<RL	<RL	<RL
Conclusion	--	--	--	--	Pass	Pass	Pass

Test Report No.: 168497397c 001

Page 10 of 33

Test Parameter	CAS NO	Unit	RL	Regulatory Requirement	Test No.	T020	T021
					Material No.	M118 + M119 + M147	M148
Perfluorononan-1-oic acid (PFNA)	375-95-1	mg/kg	0.01	-		< RL	< RL
Perfluorodecanoic acid (PFDA)	335-76-2	mg/kg	0.01	-		< RL	< RL
Perfluoroundecanoic acid (PFUnA)	2058-94-8	mg/kg	0.01	-		< RL	< RL
Perfluorododecanoic acid (PFDoA)	307-55-1	mg/kg	0.01	-		< RL	< RL
Perfluorotridecanoic acid (PFTrA)	72629-94-8	mg/kg	0.01	-		< RL	< RL
Perfluorotetradecanoic acid (PFTeA)	376-06-7	mg/kg	0.01	-		< RL	< RL
Perfluoro-3,7-dimethyloctanoic acid (PF-3,7-DMOA)	172155-07-6	mg/kg	0.01	-		< RL	< RL
Sum of C9-C14 PFCAs	--	mg/kg	--	0.025		<RL	<RL
1H,1H,2H,2H-Perfluoro-1-decanol (8:2 FTOH)	678-39-7	mg/kg	0.25	-		< RL	< RL
1H,1H,2H,2H-Perfluoro-1-dodecanol (10:2 FTOH)	865-86-1	mg/kg	0.25	-		< RL	< RL
Perfluorodecanesulfonate (PFDS)	335-77-3	mg/kg	0.01	-		< RL	< RL
2H,2H,3H,3H-Perfluoroundecanoic acid (H4PFUnA)	34598-33-9	mg/kg	0.01	-		< RL	< RL
1H,1H,2H,2H-Perfluorododecanesulfonic acid (10:2 FTS)	120226-60-0	mg/kg	0.1	-		< RL	< RL
1H,1H,2H,2H-Perfluorododecanesulfonic acid (8:2-FTSA)	39108-34-4	mg/kg	0.1	-		< RL	< RL
1H,1H,2H,2H-perfluorotetradecan-1-ol (12:2 FTOH)	39239-77-5	mg/kg	0.1	-		< RL	< RL
1H,1H,2H,2H-Perfluorododecylacrylate (10:2 FTA)	17741-60-5	mg/kg	0.1	-		< RL	< RL
1H, 1H, 2H, 2H-Perfluorodecyl dichloromethylsilane (C8-PFSi)	3102-79-2	mg/kg	0.1	-		< RL	< RL
8:2 Fluorotelomer olefin (8:2 FTO)	21652-58-4	mg/kg	0.1	-		< RL	< RL
1H,1H,2H,2H-Perfluorodecyl acrylate (8:2-FTA)	27905-45-9	mg/kg	0.1	-		< RL	< RL
Perfluorooctylethyl Methacrylate (8:2-FTMAC)	1996-88-9	mg/kg	0.1	-		< RL	< RL
1H,1H,2H,2H-Heptadecafluoro-1-iododecane (8:2-FTI)	2043-53-0	mg/kg	0.1	-		< RL	< RL
2-(Perfluorodecyl)ethyl methacrylate (10:2 FTMA)	2144-54-9	mg/kg	0.1	-		< RL	< RL
1H,1H,2H,2H-Perfluorododecyl iodide (10:2 FTI)	2043-54-1	mg/kg	0.1	-		< RL	< RL
1H,1H,2H,2H-Perfluorotetradecyl iodide (12:2 FTI)	30046-31-2	mg/kg	0.1	-		< RL	< RL
Sum of C9-C14 PFCA related substances	--	mg/kg	--	0.26		<RL	<RL
Conclusion	--	--	--	--		Pass	Pass

Test Report No.: 168497397c 001

Page 11 of 33

Test Parameter	CAS NO	Unit	RL	Regulatory Requirement	Test No.	T022	T023
					Material No.	M121 + M127 + M129	M161 + M162 + M167
Test Parameter	CAS NO	Unit	RL	Regulatory Requirement	Result	Result	Result
Perfluorononan-1-oic acid (PFNA)	375-95-1	mg/kg	0.01	-	< RL	< RL	< RL
Perfluorodecanoic acid (PFDA)	335-76-2	mg/kg	0.01	-	< RL	< RL	< RL
Perfluoroundecanoic acid (PFUnA)	2058-94-8	mg/kg	0.01	-	< RL	< RL	< RL
Perfluorododecanoic acid (PFDoA)	307-55-1	mg/kg	0.01	-	< RL	< RL	< RL
Perfluorotridecanoic acid (PFTrA)	72629-94-8	mg/kg	0.01	-	< RL	< RL	< RL
Perfluorotetradecanoic acid (PFTeA)	376-06-7	mg/kg	0.01	-	< RL	< RL	< RL
Perfluoro-3,7-dimethyloctanoic acid (PF-3,7-DMOA)	172155-07-6	mg/kg	0.01	-	< RL	< RL	< RL
Sum of C9-C14 PFCAs	--	mg/kg	--	0.025	<RL	<RL	<RL
1H,1H,2H,2H-Perfluoro-1-decanol (8:2 FTOH)	678-39-7	mg/kg	0.25	-	< RL	< RL	< RL
1H,1H,2H,2H-Perfluoro-1-dodecanol (10:2 FTOH)	865-86-1	mg/kg	0.25	-	< RL	< RL	< RL
Perfluorodecanesulfonate (PFDS)	335-77-3	mg/kg	0.01	-	< RL	< RL	< RL
2H,2H,3H,3H-Perfluoroundecanoic acid (H4PFUnA)	34598-33-9	mg/kg	0.01	-	< RL	< RL	< RL
1H,1H,2H,2H-Perfluorododecanesulfonic acid (10:2 FTS)	120226-60-0	mg/kg	0.1	-	< RL	< RL	< RL
1H,1H,2H,2H-Perfluorododecanesulfonic acid (8:2-FTSA)	39108-34-4	mg/kg	0.1	-	< RL	< RL	< RL
1H,1H,2H,2H-perfluorotetradecan-1-ol (12:2 FTOH)	39239-77-5	mg/kg	0.1	-	< RL	< RL	< RL
1H,1H,2H,2H-Perfluorododecylacrylate (10:2 FTA)	17741-60-5	mg/kg	0.1	-	< RL	< RL	< RL
1H, 1H, 2H, 2H-Perfluorodecylchloromethylsilane (C8-PFSi)	3102-79-2	mg/kg	0.1	-	< RL	< RL	< RL
8:2 Fluorotelomer olefin (8:2 FTO)	21652-58-4	mg/kg	0.1	-	< RL	< RL	< RL
1H,1H,2H,2H-Perfluorodecyl acrylate (8:2-FTA)	27905-45-9	mg/kg	0.1	-	< RL	< RL	< RL
Perfluorooctylethyl Methacrylate (8:2-FTMAC)	1996-88-9	mg/kg	0.1	-	< RL	< RL	< RL
1H,1H,2H,2H-Heptadecafluoro-1-iododecane (8:2-FTI)	2043-53-0	mg/kg	0.1	-	< RL	< RL	< RL
2-(Perfluorodecyl)ethyl methacrylate (10:2 FTMA)	2144-54-9	mg/kg	0.1	-	< RL	< RL	< RL
1H,1H,2H,2H-Perfluorododecyl iodide (10:2 FTI)	2043-54-1	mg/kg	0.1	-	< RL	< RL	< RL
1H,1H,2H,2H-Perfluorotetradecyl iodide (12:2 FTI)	30046-31-2	mg/kg	0.1	-	< RL	< RL	< RL
Sum of C9-C14 PFCA related substances	--	mg/kg	--	0.26	<RL	<RL	<RL
Conclusion	--	--	--	--	Pass	Pass	Pass

Test Report No.: 168497397c 001

Page 12 of 33

					Test No.	T024
					Material No.	M166 + M168
Test Parameter	CAS NO	Unit	RL	Regulatory Requirement	Result	
Perfluorononan-1-oic acid (PFNA)	375-95-1	mg/kg	0.01	-	< RL	
Perfluorodecanoic acid (PFDA)	335-76-2	mg/kg	0.01	-	< RL	
Perfluoroundecanoic acid (PFUnA)	2058-94-8	mg/kg	0.01	-	< RL	
Perfluorododecanoic acid (PFDoA)	307-55-1	mg/kg	0.01	-	< RL	
Perfluorotridecanoic acid (PFTrA)	72629-94-8	mg/kg	0.01	-	< RL	
Perfluorotetradecanoic acid (PFTeA)	376-06-7	mg/kg	0.01	-	< RL	
Perfluoro-3,7-dimethyloctanoic acid (PF-3,7-DMOA)	172155-07-6	mg/kg	0.01	-	< RL	
Sum of C9-C14 PFCAs	--	mg/kg	--	0.025	<RL	
1H,1H,2H,2H-Perfluoro-1-decanol (8:2 FTOH)	678-39-7	mg/kg	0.25	-	< RL	
1H,1H,2H,2H-Perfluoro-1-dodecanol (10:2 FTOH)	865-86-1	mg/kg	0.25	-	< RL	
Perfluorodecanesulfonate (PFDS)	335-77-3	mg/kg	0.01	-	< RL	
2H,2H,3H,3H-Perfluoroundecanoic acid (H4PFUnA)	34598-33-9	mg/kg	0.01	-	< RL	
1H,1H,2H,2H-Perfluorododecanesulfonic acid (10:2 FTS)	120226-60-0	mg/kg	0.1	-	< RL	
1H,1H,2H,2H-Perfluorodecanesulfonic acid (8:2-FTSA)	39108-34-4	mg/kg	0.1	-	< RL	
1H,1H,2H,2H-perfluorotetradecan-1-ol (12:2 FTOH)	39239-77-5	mg/kg	0.1	-	< RL	
1H,1H,2H,2H-Perfluorododecylacrylate (10:2 FTA)	17741-60-5	mg/kg	0.1	-	< RL	
1H, 1H, 2H, 2H-Perfluorodecyl dichloromethylsilane (C8-PFSi)	3102-79-2	mg/kg	0.1	-	< RL	
8:2 Fluorotelomer olefin (8:2 FTO)	21652-58-4	mg/kg	0.1	-	< RL	
1H,1H,2H,2H-Perfluorodecyl acrylate (8:2-FTA)	27905-45-9	mg/kg	0.1	-	< RL	
Perfluorooctylethyl Methacrylate (8:2-FTMAC)	1996-88-9	mg/kg	0.1	-	< RL	
1H,1H,2H,2H-Heptadecafluoro-1-iododecane (8:2-FTI)	2043-53-0	mg/kg	0.1	-	< RL	
2-(Perfluorodecyl)ethyl methacrylate (10:2 FTMA)	2144-54-9	mg/kg	0.1	-	< RL	
1H,1H,2H,2H-Perfluorododecyl iodide (10:2 FTI)	2043-54-1	mg/kg	0.1	-	< RL	
1H,1H,2H,2H-Perfluorotetradecyl iodide (12:2 FTI)	30046-31-2	mg/kg	0.1	-	< RL	
Sum of C9-C14 PFCA related substances	--	mg/kg	--	0.26	<RL	
Conclusion	--	--	--	--	Pass	

Abbreviation: < = Less than
 RL = Reporting Limit
 mg/kg = milligram per kilogram

Test Report No.: 168497397c 001

Page 13 of 33

Remark:

- * Requirements according to Annex XVII of Regulation (EC) No 1907/2006 entry 68 (REACH) for perfluorinated carboxylic acids (C9-C14-PFCA) their salts and C9-C14-PFCA related substances amended by Regulation (EU) 2021/1297.
Shall not be used or placed on the market after 25 February 2023:
 - (a) another substance, as a constituent;
 - (b) in a mixture;
 - (c) in an article,except if the concentration in the substance, the mixture, or the article is below 25 ppb for the sum of C9-C14 PFCA and their salts or 260 ppb for the sum of C9-C14 PFCA-related substances.

4.Organotin compounds content

 Test Method: Organic solvent extraction, GCMS
 Ref. to ISO/TS 16179:2012

Test No.				T015	T016	T017
Material No.				M111 + M112 + M113	M115 + M119	M123 + M124 + M126
Test Parameter	Unit	RL	Regulatory Requirement	Result	Result	Result
TBT(Tributyltin) by weight of tin	%	0.01	--	< RL	< RL	< RL
TPT(Triphenyltin) by weight of tin	%	0.01	--	< RL	< RL	< RL
TOT(Trioctyltin) by weight of tin	%	0.01	--	< RL	< RL	< RL
TCyT(Tricyclohexyltin) by weight of tin	%	0.01	--	< RL	< RL	< RL
TPrT(Tripopyltin) by weight of tin	%	0.01	--	< RL	< RL	< RL
Sum of Tin of tri-substituted organotins	%	NA	0.1	< RL	< RL	< RL
DBT(Dibutyltin) by weight of tin	%	0.01	0.1	< RL	< RL	< RL
DOT(Dioctyltin) by weight of tin	%	0.01	0.1	< RL	< RL	< RL

Test No.				T018	T019	T020
Material No.				M130 + M131 + M134	M135 + M136 + M137	M138 + M139 + M140
Test Parameter	Unit	RL	Regulatory Requirement	Result	Result	Result
TBT(Tributyltin) by weight of tin	%	0.01	--	< RL	< RL	< RL
TPT(Triphenyltin) by weight of tin	%	0.01	--	< RL	< RL	< RL
TOT(Trioctyltin) by weight of tin	%	0.01	--	< RL	< RL	< RL
TCyT(Tricyclohexyltin) by weight of tin	%	0.01	--	< RL	< RL	< RL
TPrT(Tripopyltin) by weight of tin	%	0.01	--	< RL	< RL	< RL
Sum of Tin of tri-substituted organotins	%	NA	0.1	< RL	< RL	< RL
DBT(Dibutyltin) by weight of tin	%	0.01	0.1	< RL	< RL	< RL
DOT(Dioctyltin) by weight of tin	%	0.01	0.1	< RL	< RL	< RL

Test Report No.: 168497397c 001

Page 15 of 33

				Test No.	T021	T022	T023
				Material No.	M141 + M142 + M143	M161	M158
Test Parameter	Unit	RL	Regulatory Requirement	Result	Result	Result	
TBT(Tributyltin) by weight of tin	%	0.01	--	< RL	< RL	< RL	
TPT(Triphenyltin) by weight of tin	%	0.01	--	< RL	< RL	< RL	
TOT(Trioctyltin) by weight of tin	%	0.01	--	< RL	< RL	< RL	
TCyT(Tricyclohexyltin) by weight of tin	%	0.01	--	< RL	< RL	< RL	
TPrT(Tripopyltin) by weight of tin	%	0.01	--	< RL	< RL	< RL	
Sum of Tin of tri-substituted organotins	%	NA	0.1	< RL	< RL	< RL	
DBT(Dibutyltin) by weight of tin	%	0.01	0.1	< RL	< RL	< RL	
DOT(Dioctyltin) by weight of tin	%	0.01	0.1	< RL	< RL	< RL	

Abbreviation: < = less than
 RL = Reporting Limit
 % = percentage
 NA = Not Applicable

Test Report No.: 168497397c 001 Page 16 of 33

Remark:

- * Single components with an amount of <0.01% were not considered in the calculation of the sum. In the case of all five tri-substituted organotins were not detected, the result is stated < RL
- ** The assessment for tri-substituted organotins is based on the sum of TBT, TPT, TOT, TCyT and TPtT by weight of tin only.
- *** According to REACH Regulation (EC) No. 1907/2006 Annex XVII Entry 20 and amendment Commission Regulation (EU) No. 276/2010 (formerly known as 2009/425/EC), organostannic compounds shall not be used or be placed on the market.

Type of organostannic compounds	Maximum Permissible Limit	Implementation date
Tri-substituted organostannic compounds, e.g. tributyltin (TBT) compounds and triphenyltin (TPT) compounds	0.1 % by weight of tin	1 July 2010
Dibutyltin (DBT) compounds in mixtures and articles for supply to the general public	0.1 % by weight of tin	1 January 2012 The below products will not be applicable until 1 January 2015: - one-component and two-component room temperature vulcanisation sealants (RTV-1 and RTV-2 sealants) and adhesives, - paints and coatings containing DBT compounds as catalysts when applied on articles, - soft polyvinyl chloride (PVC) profiles whether by themselves or coextruded with hard PVC, - fabrics coated with PVC containing DBT compounds as stabilisers when intended for outdoor applications, - outdoor rainwater pipes, gutters and fittings, as well as covering material for roofing and facades
Dioctyltin (DOT) compounds - textile articles intended to come into contact with the skin, - gloves, - footwear or part of footwear intended to come into contact with the skin, - wall and floor coverings - childcare articles, - female hygiene products, - nappies, - two-component room temperature vulcanisation moulding kits (RTV-2 moulding kits)	0.1 % by weight of tin	1 January 2012

5. Octabromodiphenylether (OctaBDE) content

Test Method: Organic solvent extraction, analyzed by GCMS & LCMS

Test No.					T033	T034
Material No.:					M111 + M112 + M113	M114 + M115 + M116
Test Parameter	CAS No.	Unit	RL	Regulatory Requirement	Result	Result
Octabromodiphenylether (OctaBDE)	32536-52-0	mg/kg	50	1000	< RL	< RL

Test No.					T035	T036
Material No.:					M117 + M118 + M119	M120 + M122 + M123
Test Parameter	CAS No.	Unit	RL	Regulatory Requirement	Result	Result
Octabromodiphenylether (OctaBDE)	32536-52-0	mg/kg	50	1000	< RL	< RL

Test No.					T037	T038
Material No.:					M121 + M127 + M129	M124 + M125 + M126
Test Parameter	CAS No.	Unit	RL	Regulatory Requirement	Result	Result
Octabromodiphenylether (OctaBDE)	32536-52-0	mg/kg	50	1000	< RL	< RL

Test No.					T039	T040
Material No.:					M128 + M130 + M131	M132 + M133 + M134
Test Parameter	CAS No.	Unit	RL	Regulatory Requirement	Result	Result
Octabromodiphenylether (OctaBDE)	32536-52-0	mg/kg	50	1000	< RL	< RL

Test No.					T041	T042
Material No.:					M135 + M136 + M137	M138 + M139 + M140
Test Parameter	CAS No.	Unit	RL	Regulatory Requirement	Result	Result
Octabromodiphenylether (OctaBDE)	32536-52-0	mg/kg	50	1000	< RL	< RL

Test Report No.: 168497397c 001

Page 18 of 33

Test No.					T043	T044
Material No.:					M141 + M142 + M143	M144 + M145
Test Parameter	CAS No.	Unit	RL	Regulatory Requirement	Result	Result
Octabromodiphenylether (OctaBDE)	32536-52-0	mg/kg	50	1000	< RL	< RL

Test No.					T045	T046
Material No.:					M146 + M147 + M148	M161 + M162 + M164
Test Parameter	CAS No.	Unit	RL	Regulatory Requirement	Result	Result
Octabromodiphenylether (OctaBDE)	32536-52-0	mg/kg	50	1000	< RL	< RL

Test No.					T047	T048
Material No.:					M163 + M165 + M167	M157 + M158 + M159
Test Parameter	CAS No.	Unit	RL	Regulatory Requirement	Result	Result
Octabromodiphenylether (OctaBDE)	32536-52-0	mg/kg	50	1000	< RL	< RL

Abbreviation: < = less than
 RL = Reporting Limit
 mg/kg = milligram per kilogram

Test Report No.: 168497397c 001

Page 19 of 33

6. Phthalates content

Test Method: Ref. to IEC 62321-8:2017

Parameter	CAS No.	Unit	Test No.	T034	T035	T036
			Material No.:	M111 + M112 + M113	M114 + M115 + M116	M117 + M118 + M119
			RL	Result	Result	Result
Diethylhexyl phthalate (DEHP)	117-81-7	%	0.01	<RL	<RL	<RL
Dibutyl phthalate (DBP)	84-74-2	%	0.01	<RL	<RL	<RL
Benzylbutyl phthalate (BBP)	85-68-7	%	0.01	<RL	<RL	<RL
Diisobutyl phthalate (DIBP)	84-69-5	%	0.01	<RL	<RL	<RL
Sum (DEHP+DBP+BBP+DIBP)	--	%	0.01	<RL	<RL	<RL
Conclusion: REACH regulation (EC) No. 1907/2006 and its amendment Annex XVII entries 51				Pass	Pass	Pass

Parameter	CAS No.	Unit	Test No.	T037	T038	T039
			Material No.:	M120 + M122 + M123	M121 + M127 + M129	M124 + M125 + M126
			RL	Result	Result	Result
Diethylhexyl phthalate (DEHP)	117-81-7	%	0.01	0.01	0.01	<RL
Dibutyl phthalate (DBP)	84-74-2	%	0.01	0.03	0.03	<RL
Benzylbutyl phthalate (BBP)	85-68-7	%	0.01	<RL	<RL	<RL
Diisobutyl phthalate (DIBP)	84-69-5	%	0.01	<RL	<RL	<RL
Sum (DEHP+DBP+BBP+DIBP)	--	%	0.01	<RL	<RL	<RL
Conclusion: REACH regulation (EC) No. 1907/2006 and its amendment Annex XVII entries 51				Pass	Pass	Pass

Test Report No.: 168497397c 001

Page 20 of 33

Parameter	CAS No.	Unit	Test No.	T040	T041	T042
			Material No.:	M128 + M130 + M131	M132 + M133 + M134	M135 + M136 + M137
			RL	Result	Result	Result
Diethylhexyl phthalate (DEHP)	117-81-7	%	0.01	<RL	<RL	<RL
Dibutyl phthalate (DBP)	84-74-2	%	0.01	<RL	<RL	<RL
Benzylbutyl phthalate (BBP)	85-68-7	%	0.01	<RL	<RL	<RL
Diisobutyl phthalate (DIBP)	84-69-5	%	0.01	<RL	<RL	<RL
Sum (DEHP+DBP+BBP+DIBP)	--	%	0.01	<RL	<RL	<RL
Conclusion: REACH regulation (EC) No. 1907/2006 and its amendment Annex XVII entries 51				Pass	Pass	Pass

Parameter	CAS No.	Unit	Test No.	T043	T044	T045
			Material No.:	M138 + M139 + M140	M141 + M142 + M143	M144 + M145
			RL	Result	Result	Result
Diethylhexyl phthalate (DEHP)	117-81-7	%	0.01	<RL	<RL	<RL
Dibutyl phthalate (DBP)	84-74-2	%	0.01	<RL	<RL	<RL
Benzylbutyl phthalate (BBP)	85-68-7	%	0.01	<RL	<RL	<RL
Diisobutyl phthalate (DIBP)	84-69-5	%	0.01	<RL	<RL	<RL
Sum (DEHP+DBP+BBP+DIBP)	--	%	0.01	<RL	<RL	<RL
Conclusion: REACH regulation (EC) No. 1907/2006 and its amendment Annex XVII entries 51				Pass	Pass	Pass

Parameter	CAS No.	Unit	Test No.	T046	T047	T048
			Material No.:	M146 + M147 + M148	M161 + M162 + M164	M163 + M165 + M167
			RL	Result	Result	Result
Diethylhexyl phthalate (DEHP)	117-81-7	%	0.01	<RL	<RL	<RL
Dibutyl phthalate (DBP)	84-74-2	%	0.01	0.02	<RL	<RL
Benzylbutyl phthalate (BBP)	85-68-7	%	0.01	<RL	<RL	<RL
Diisobutyl phthalate (DIBP)	84-69-5	%	0.01	<RL	<RL	<RL
Sum (DEHP+DBP+BBP+DIBP)	--	%	0.01	<RL	<RL	<RL

Test Report No.: 168497397c 001

Page 21 of 33

			Test No.	T046	T047	T048
Parameter	CAS No.	Unit	Material No.:	M146 + M147 + M148	M161 + M162 + M164	M163 + M165 + M167
			RL	Result	Result	Result
Conclusion: REACH regulation (EC) No. 1907/2006 and its amendment Annex XVII entries 51				Pass	Pass	Pass

			Test No.	T049
Parameter	CAS No.	Unit	Material No.:	M157 + M158 + M159
			RL	Result
Diethylhexyl phthalate (DEHP)	117-81-7	%	0.01	<RL
Dibutyl phthalate (DBP)	84-74-2	%	0.01	<RL
Benzylbutyl phthalate (BBP)	85-68-7	%	0.01	<RL
Diisobutyl phthalate (DIBP)	84-69-5	%	0.01	<RL
Sum (DEHP+DBP+BBP+DIBP)	--	%	0.01	<RL
Conclusion: REACH regulation (EC) No. 1907/2006 and its amendment Annex XVII entries 51				Pass

Abbreviation: < = less than
 RL = Reporting Limit
 % = percentage

Remark:

- Requirement of REACH regulation (EC) No. 1907/2006 and its amendment Annex XVII entries 51:

Parameter	Unit	Maximum Permissible Limit
Plasticised materials in toys and childcare articles, or other articles# place on the market;		
Diethylhexyl phthalate (DEHP) Dibutyl phthalate (DBP) Benzylbutyl phthalate (BBP) Diisobutyl phthalate (DIBP)	%	0.1 (individually or sum of the four phthalates) Effective after 7 July 2020.

Denote:

Examples of articles that are excluded from the restriction

- Articles exclusively for industrial / agricultural use / use in open air, provided that no plasticised material comes into contact with human mucous membranes or into prolonged contact with human skin (i.e.

Test Report No.: 168497397c 001

Page 22 of 33

Continuous contact of more than 10 minutes duration or intermittent contact over a period of 30 minute per day.)

- 2) Aircraft and motor vehicles (Directive 2007/46/EC) placed on the market before 7 January 2024, or articles for use exclusively in the maintenance or repair of them
- 3) Measuring devices for laboratory use;
- 4) Food contact material and articles within the scope of Regulation (EC) No 1935/2004 or Commission Regulation (EU) No 10/2011
- 5) Medical devices (Directive 90/385/EEC, 93/42/EEC or 98/79/EC)
- 6) Electrical and electronic equipment within the scope of Directive 2011/65/EU
- 7) Immediate packaging of medicinal products (Regulation (EC) No 726/2004, Directive 2001/82/EC or Directive 2001/83/EC)

7. Dimethyl fumarate (CAS No.624-49-7)

Test Method: Organic solvent extraction, GCMS analysis

Test Result:

Test No.	Material No.	Test Parameter	Unit	RL	Regulatory Requirement	Test Result
T010	M113 + M115 + M147	Dimethyl fumarate	mg/kg	0.025	0.1	< RL
T011	M148	Dimethyl fumarate	mg/kg	0.025	0.1	< RL
T012	M161 + M162 + M167	Dimethyl fumarate	mg/kg	0.025	0.1	< RL

Abbreviation: < = less than
 RL = Reporting Limit
 mg/kg = milligram per kilogram

Remark:

- * According to REACH Regulation (EC) No. 1907/2006 Annex XVII Item 61 and amendment Commission Regulation (EU) No. 412/2012 (formerly known as 2012/48/EU), dimethylfumarate (DMF) shall not be used in articles or any parts thereof in concentrations greater than 0.1 mg/kg. Articles or any parts thereof containing DMF in concentrations greater than 0.1 mg/kg shall not be placed on the market.

8. Polycyclic aromatic hydrocarbons (PAHs)

Test Method: Organic solvent extraction, GCMS

					Test No.	T005	T006	T007
					Material No.	M111 + M112 + M113	M119	M161
Test Parameter	CAS NO	Unit	RL	Regulatory Requirement	Result	Result	Result	
Benzo[a]anthracene (BaA)	56-55-3	mg/kg	0.2	1	< RL	< RL	< RL	
Benzo[a]pyrene (BaP)	50-32-8	mg/kg	0.2	1	< RL	< RL	< RL	
Benzo[b]fluoranthene (BbFA)	205-99-2	mg/kg	0.2	1	< RL	< RL	< RL	
Benzo[k]fluoranthene (BkFA)	207-08-9	mg/kg	0.2	1	< RL	< RL	< RL	
Benzo[j]fluoranthene (BjFA)	205-82-3	mg/kg	0.2	1	< RL	< RL	< RL	
Benzo[e]pyrene (BeP)	192-97-2	mg/kg	0.2	1	< RL	< RL	< RL	
Chrysene (CHR)	218-01-9	mg/kg	0.2	1	< RL	< RL	< RL	
Dibenzo[a,h]anthracene (DBAhA)	53-70-3	mg/kg	0.2	1	< RL	< RL	< RL	

					Test No.	T008
					Material No.	M158
Test Parameter	CAS NO	Unit	RL	Regulatory Requirement	Result	
Benzo[a]anthracene (BaA)	56-55-3	mg/kg	0.2	1	< RL	
Benzo[a]pyrene (BaP)	50-32-8	mg/kg	0.2	1	< RL	
Benzo[b]fluoranthene (BbFA)	205-99-2	mg/kg	0.2	1	< RL	
Benzo[k]fluoranthene (BkFA)	207-08-9	mg/kg	0.2	1	< RL	
Benzo[j]fluoranthene (BjFA)	205-82-3	mg/kg	0.2	1	< RL	
Benzo[e]pyrene (BeP)	192-97-2	mg/kg	0.2	1	< RL	
Chrysene (CHR)	218-01-9	mg/kg	0.2	1	< RL	
Dibenzo[a,h]anthracene (DBAhA)	53-70-3	mg/kg	0.2	1	< RL	

Abbreviation: < = less than
 RL = Reporting Limit
 NA = Not Applicable
 mg/kg = milligram per kilogram

Test Report No.: 168497397c 001 Page 25 of 33

Remark:

* Requirement according to REACH regulation (EC) No. 1907/2006 with Amendment No. 552/2009 Annex XVII Item No. 50 and (EU) No.1272/2013, are summarized as below:

Scope	Parameter	Unit	Maximum permissible limit
Articles with direct as well as prolonged or short-term repetitive contact with the human skin or the oralcavity, under normal or reasonably foreseeable conditions of use ,made of plastic and rubber shall follow below limit:			
Such articles include amongst others: ---sport equipment such as bicycles, golf clubs, racquets ---household utensils, trolleys, walking frames --- tools for domestic use --- clothing, footwear, gloves and sportswear ---watch-straps, wrist-bands, masks, head-bands	Each of 8 listed PAHs	mg/kg	1
Toys, including activity toys, and childcare articles	Each of 8 listed PAHs	mg/kg	0.5

9. Phenylmercury Compounds

Test Method: Acid digestion, analyzed by ICP-MS

					Test No.	T033	T034	T035
					Material No.	M111 + M112 + M113	M114 + M115 + M116	M117 + M118 + M119
Test Parameter	CAS No.	Unit	RL	Formulation Limit	Result	Result	Result	
Phenylmercury acetate (by weight of Mercury)	62-38-4	%	0.005	0.01	< RL	< RL	< RL	
Phenylmercury propionate (by weight of Mercury)	103-27-5	%	0.005	0.01	< RL	< RL	< RL	
Phenylmercury 2-ethylhexanoate (by weight of Mercury)	13302-00-6	%	0.005	0.01	< RL	< RL	< RL	
Phenylmercury octanoate (by weight of Mercury)	13864-38-5	%	0.005	0.01	< RL	< RL	< RL	
Phenylmercury neodecanoate (by weight of Mercury)	26545-49-3	%	0.005	0.01	< RL	< RL	< RL	

					Test No.	T036	T037	T038
					Material No.	M120 + M122 + M123	M121 + M127 + M129	M124 + M125 + M126
Test Parameter	CAS No.	Unit	RL	Formulation Limit	Result	Result	Result	
Phenylmercury acetate (by weight of Mercury)	62-38-4	%	0.005	0.01	< RL	< RL	< RL	
Phenylmercury propionate (by weight of Mercury)	103-27-5	%	0.005	0.01	< RL	< RL	< RL	
Phenylmercury 2-ethylhexanoate (by weight of Mercury)	13302-00-6	%	0.005	0.01	< RL	< RL	< RL	
Phenylmercury octanoate (by weight of Mercury)	13864-38-5	%	0.005	0.01	< RL	< RL	< RL	
Phenylmercury neodecanoate (by weight of Mercury)	26545-49-3	%	0.005	0.01	< RL	< RL	< RL	

Test Report No.: 168497397c 001

Page 27 of 33

					Test No.	T039	T040	T041
					Material No.	M128 + M130 + M131	M132 + M133 + M134	M135 + M136 + M137
Test Parameter	CAS No.	Unit	RL	Formulation Limit	Result	Result	Result	
Phenylmercury acetate (by weight of Mercury)	62-38-4	%	0.005	0.01	< RL	< RL	< RL	
Phenylmercury propionate (by weight of Mercury)	103-27-5	%	0.005	0.01	< RL	< RL	< RL	
Phenylmercury 2-ethylhexanoate (by weight of Mercury)	13302-00-6	%	0.005	0.01	< RL	< RL	< RL	
Phenylmercury octanoate (by weight of Mercury)	13864-38-5	%	0.005	0.01	< RL	< RL	< RL	
Phenylmercury neodecanoate (by weight of Mercury)	26545-49-3	%	0.005	0.01	< RL	< RL	< RL	

					Test No.	T042	T043	T044
					Material No.	M138 + M139 + M140	M141 + M142 + M143	M144 + M145
Test Parameter	CAS No.	Unit	RL	Formulation Limit	Result	Result	Result	
Phenylmercury acetate (by weight of Mercury)	62-38-4	%	0.005	0.01	< RL	< RL	< RL	
Phenylmercury propionate (by weight of Mercury)	103-27-5	%	0.005	0.01	< RL	< RL	< RL	
Phenylmercury 2-ethylhexanoate (by weight of Mercury)	13302-00-6	%	0.005	0.01	< RL	< RL	< RL	
Phenylmercury octanoate (by weight of Mercury)	13864-38-5	%	0.005	0.01	< RL	< RL	< RL	
Phenylmercury neodecanoate (by weight of Mercury)	26545-49-3	%	0.005	0.01	< RL	< RL	< RL	

Test Report No.: 168497397c 001

Page 28 of 33

					Test No.	T045	T046	T047
					Material No.	M146 + M147 + M148	M161 + M162 + M164	M163 + M165 + M167
Test Parameter	CAS No.	Unit	RL	Formulation Limit	Result	Result	Result	
Phenylmercury acetate (by weight of Mercury)	62-38-4	%	0.005	0.01	< RL	< RL	< RL	
Phenylmercury propionate (by weight of Mercury)	103-27-5	%	0.005	0.01	< RL	< RL	< RL	
Phenylmercury 2-ethylhexanoate (by weight of Mercury)	13302-00-6	%	0.005	0.01	< RL	< RL	< RL	
Phenylmercury octanoate (by weight of Mercury)	13864-38-5	%	0.005	0.01	< RL	< RL	< RL	
Phenylmercury neodecanoate (by weight of Mercury)	26545-49-3	%	0.005	0.01	< RL	< RL	< RL	

					Test No.	T048
					Material No.	M157 + M158 + M159
Test Parameter	CAS No.	Unit	RL	Formulation Limit	Result	
Phenylmercury acetate (by weight of Mercury)	62-38-4	%	0.005	0.01	< RL	
Phenylmercury propionate (by weight of Mercury)	103-27-5	%	0.005	0.01	< RL	
Phenylmercury 2-ethylhexanoate (by weight of Mercury)	13302-00-6	%	0.005	0.01	< RL	
Phenylmercury octanoate (by weight of Mercury)	13864-38-5	%	0.005	0.01	< RL	
Phenylmercury neodecanoate (by weight of Mercury)	26545-49-3	%	0.005	0.01	< RL	

Abbreviation: RL = Reporting Limit
< = Less Than
% = Percentage

Remark:

Shall not be manufactured, placed on the market or used as substances or in mixtures if the concentration of mercury in the mixtures is equal to or greater than 0,01 % by weight.

Articles or any parts thereof containing one or more of these substances shall not be placed on the market if the concentration of mercury in the articles or any part thereof is equal to or greater than 0,01 % by weight.

10.Total Lead content

Test Method: CPSC-CH-E1001-08.3, CPSC-CH-E1002-08.3 and CPSC-CH-E1003-09.1 (Microwave method)

Test result:

Test No.	Material No.	Test Parameter	Unit	RL	Regulatory Requirement	Test Result
T033	M111 + M112 + M113	Lead Content	%	0.001	0.1	< RL
T034	M114 + M115 + M116	Lead Content	%	0.001	0.1	< RL
T035	M117 + M118 + M119	Lead Content	%	0.001	0.1	< RL
T036	M120 + M122 + M123	Lead Content	%	0.001	0.1	< RL
T037	M121 + M127 + M129	Lead Content	%	0.001	0.1	< RL
T038	M124 + M125 + M126	Lead Content	%	0.001	0.1	< RL
T039	M128 + M130 + M131	Lead Content	%	0.001	0.1	< RL
T040	M132 + M133 + M134	Lead Content	%	0.001	0.1	< RL
T041	M135 + M136 + M137	Lead Content	%	0.001	0.1	< RL
T042	M138 + M139 + M140	Lead Content	%	0.001	0.1	< RL
T043	M141 + M142 + M143	Lead Content	%	0.001	0.1	< RL
T044	M144 + M145	Lead Content	%	0.001	0.1	< RL
T045	M146 + M147 + M148	Lead Content	%	0.001	0.1	< RL

Abbreviation: < = less than
 RL = Reporting Limit
 % = Percentage

Sample Photos

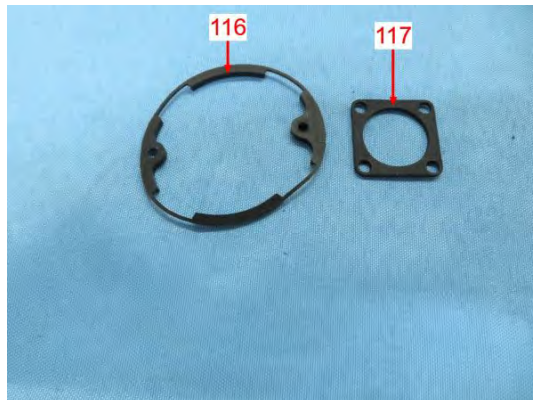

Test Report No.: 168497397c 001 Page 31 of 33

Sample Photos

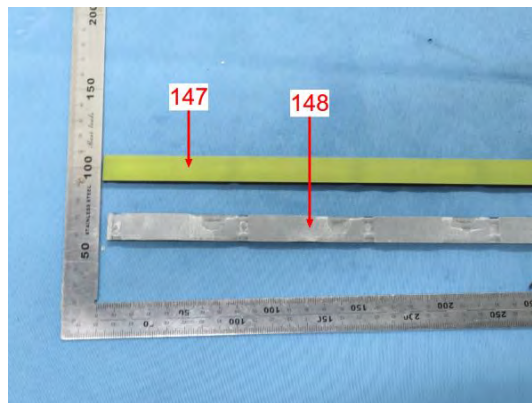
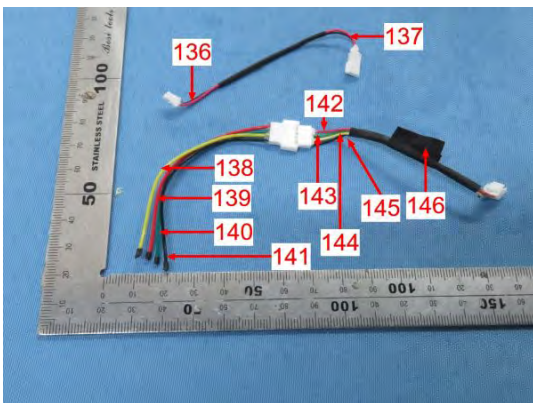
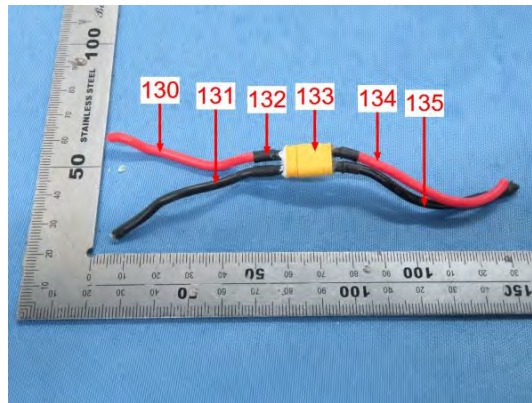
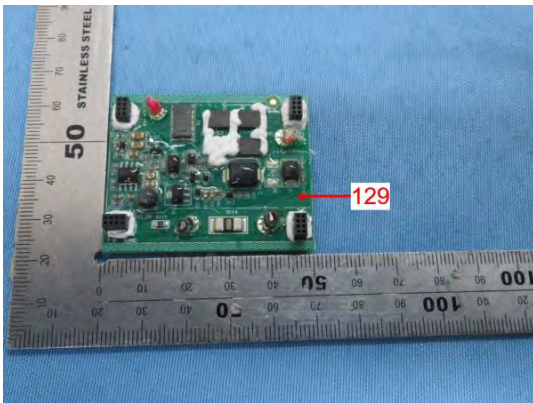
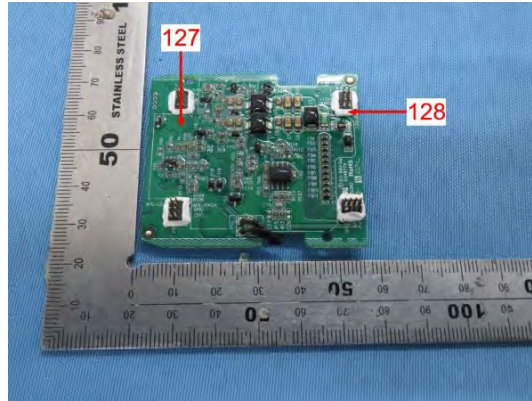
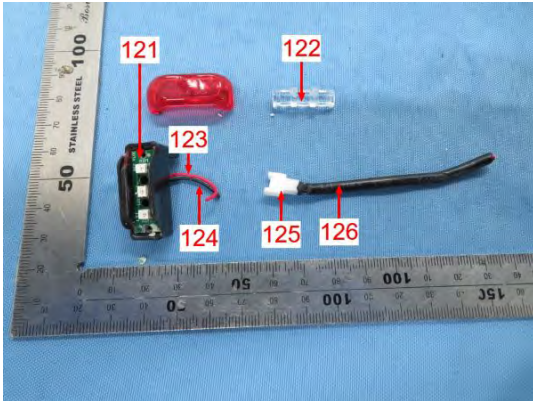

Sample Photos

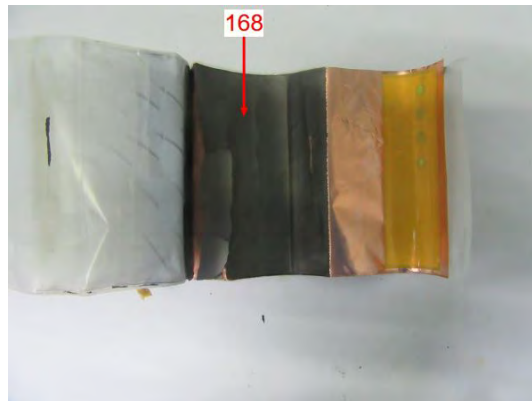
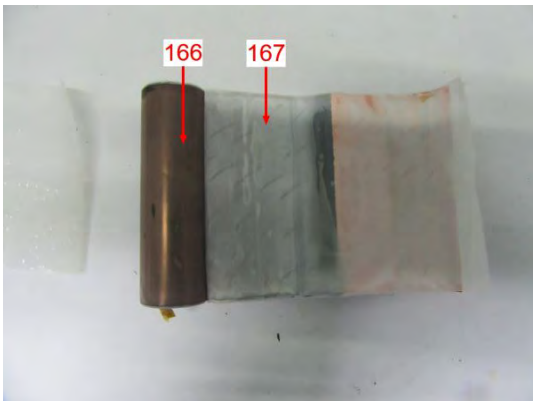
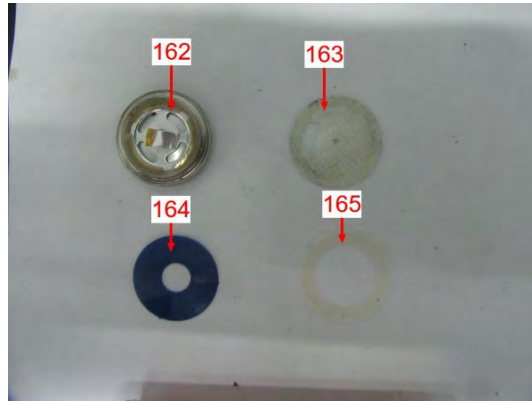
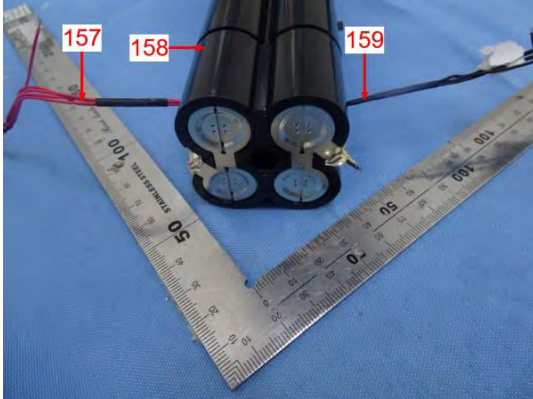

Sample Photo



Product

- END -

General Terms and Conditions of Business of TÜV Rheinland in Greater China

1. Scope

1.1 These General Terms and Conditions of Business of TÜV Rheinland in Greater China ("GTBCB") is made between the client and one or more persons or entities in Greater China as applicable as the case may be ("TÜV Rheinland"). The Greater China here refers to the regions within the territories of China. The client here includes:

- (i) a natural person capable to form legally binding contracts under the applicable laws who concludes the contract for the purpose of a fully or partially automated production;
 - (ii) the incorporated or unincorporated entity duly organized, validly existing and capable to form legally binding contracts under the applicable law.
- 1.2 The following terms and conditions apply to agreed services including consultancy services, information, deliveries and similar services as well as ancillary services and other secondary obligations provided within the scope of contract performance.
- 1.3 Any standard terms and conditions of the client if any nature shall not apply and shall hereby be expressly excluded. No standard contractual terms and conditions of the client shall form part of the contract even if TÜV Rheinland does not explicitly object to them.
- 1.4 In the context of ongoing business relations with the client, this GTBCB shall also apply to future contracts with the client without TÜV Rheinland having to refer to them separately in each individual case.

2. Quotations

Unless otherwise agreed, all quotations submitted by TÜV Rheinland can be changed by TÜV Rheinland without notice prior to its acceptance and confirmation by the other party.

3. Coming into effect and duration of contracts

3.1 The contract shall come into effect for the agreed terms upon the quotation letter of TÜV Rheinland or a separate contractual document being signed by both contracting parties, or upon the acceptance requested by the client being carried out by TÜV Rheinland. If the client instructs TÜV Rheinland without receiving a quotation from TÜV Rheinland (quotation), TÜV Rheinland is, in its sole discretion, entitled to accept the order by giving written notice of such acceptance (including notice sent via electronic means) or by performing the requested services.

3.2 The contract term starts upon the coming into effect of the contract in accordance with article 3.1 and shall continue for the term agreed in the contract.

3.3 If the contract provides for an extension of the contract term, the contract term will be extended by the term provided for in the contract in writing by either party with a three-month notice prior to the end of the contractual term.

4. Scope of services

4.1 The scope and type of the services to be provided by TÜV Rheinland shall be specified in the contractually agreed service scope of TÜV Rheinland by both parties. If no such separate service scope of TÜV Rheinland exists, then the written confirmation of order by TÜV Rheinland shall be decisive for the service to be provided. Unless otherwise agreed, services beyond the scope of the service description (e.g. checking of control parts, products, production, installations, organizations not listed in the service description, as well as the intended use and application of such) are not covered. In particular, no responsibility is assumed for the design, selection of materials, construction or intended use of an examined part, product, process or plant, unless this is expressly stated in the order.

4.2 The agreed services shall be performed in compliance with the regulations in force at the time the contract is entered into.

4.3 TÜV Rheinland is entitled to determine, in its sole discretion, the method and nature of the assessment unless otherwise agreed in writing or if mandatory provisions require a specific procedure to be followed.

4.4 On execution of the work there shall be no simultaneous assumption of any guarantee of the correctness (proper quality) and working order of either tested or examined parts nor of the installation as a whole by the upstream and/or downstream processes, organizations, users and application in accordance with regulations, nor of the systems on which the installation is based. In particular, TÜV Rheinland shall assume no responsibility for the construction, selection of design, installation or maintenance of the installations examined, nor for their use and application in accordance with regulations, unless these questions are expressly covered by the contract.

4.5 In the case of inspection work, TÜV Rheinland shall not be responsible for the accuracy or checking of the safety programmes or safety regulations on which the inspections are based, unless otherwise expressly agreed in writing.

4.6 If mandatory legal regulations and standards or official requirements for the agreed service scope change after conclusion of the contract, with a written notice to the client, TÜV Rheinland shall be entitled to additional remuneration for resulting additional expenses.

4.7 The services to be provided by TÜV Rheinland under the contract are agreed exclusively with the client. A contract of third parties with the services of TÜV Rheinland, as well as making available of and justifying confidence in the work results (test reports and results, expert reports, etc.) is not part of the agreed services. This also applies if the client passes on work results - in full or in part - to third parties in accordance with clause 11.4.

4.8 The client understands and agrees that in order to perform the contract with TÜV Rheinland, the client may need to sign one or more contracts/agreements with a/more third party/parties) and establish legal relationships with those third party/parties) according to such contract/agreements. TÜV Rheinland is not responsible for the legal consequences of such contracts/agreements. TÜV Rheinland will provide the client as agent for such relevant services. In order to achieve the purpose of the contract, the client hereby agrees that TÜV Rheinland can also subcontract to a third party the services to be provided by TÜV Rheinland, but not its best effort responsibility and/or risk for any services to be provided by any third parties (including but not limited to the testing and/or certification services to be entrusted and/or applied for by our company on behalf of the client to testing and/or certification bodies, agency services provided by any other third party(ies), etc.). Besides, the client shall be liable in accordance with the relevant laws and regulations and/or the terms under the contract. If the client is required to provide any annual renewal/validity of the installations, testing and/or certification services results and pay additional fees in accordance with the relevant laws and regulations or the testing and certification rules, such fees are not within the scope of the contract price, the client shall timely perform the obligation to pay such fees and/or to pay the corresponding fees.

4.9 For the service control agreed in the contract, if the client requires TÜV Rheinland to deliver relevant test samples, data, etc. to any overseas laboratory or other places or sites to be designated by the client, TÜV Rheinland shall not take any responsibility for any problems during such delivery and the transportation process (including but not limited to any loss or damages of the samples and/or the materials, etc.). Besides, the relevant freight fees shall be borne by the client.

5. Performance periods/dates

5.1 The contractually agreed periods/dates of performance are based on estimates of the work involved which are prepared in line with the details provided by the client. They shall only be binding if being confirmed as binding by TÜV Rheinland in writing.

5.2 If binding periods of performance have been agreed, these periods shall not commence until the client has submitted all required documents to TÜV Rheinland.

5.3 Articles 5.1 and 5.2 also apply, even without express agreement by the client, to all extensions of agreed periods/dates of performance not caused by TÜV Rheinland.

5.4 TÜV Rheinland is not responsible for a delay in performance, in particular if the client has not fulfilled his duties to cooperate with clause 6.1 or has not done so in time and, in particular, has not provided TÜV Rheinland with all documents and information required for the performance of the service as specified in the contract.

5.5 If the performance of TÜV Rheinland is delayed due to unforeseeable circumstances such as force majeure, strikes, business disruptions, governmental regulations, transport obstacles, etc., TÜV Rheinland is entitled to postpone performance for a reasonable period of time which corresponds at least to the duration of the hindrance plus any time period which may be required to resume performance.

5.6 If the client is obliged to comply with legal, officially prescribed and/or by the accreditor prescribed deadlines, the client may cooperate in a timely manner with a reputable commercial bank in which enable the client to comply with the legal and/or officially prescribed deadlines. TÜV Rheinland assumes no responsibility in this respect unless TÜV Rheinland expressly agreed in writing specifically stating that ensuring the deadlines is the contractual obligation of TÜV Rheinland.

6. The client's obligation to cooperate

6.1 The client shall guarantee that all cooperation required on its part, its agents or third parties will be provided in good time and at no cost to TÜV Rheinland.

6.2 Design documents, supplies, auxiliary staff, etc. necessary for performance of the services shall be made available free of charge by the client. Moreover, collaborative action of the client must be undertaken in accordance with legal provisions, standards, safety regulations and accident prevention instructions. And the client represents and warrants that:

- a) it has required statutory qualifications;
 - b) the product, service or management system to be certified complies with applicable laws and regulations; and
 - c) it doesn't have any legal and dishonest behaviours or is not included in the list of Enterprises with Serious Illegal and Dishonest Acts (People's Republic of China).
- If the client breaches the aforesaid representations and warranties, TÜV Rheinland is entitled to i) immediately terminate the contract/order without prior notice; and ii) withdraw the issued testing report/certificates if any.
- 6.3 The client shall bear any additional cost incurred on account of work having to be redone or being delayed as a result of late, incorrect or incomplete information provided by or lack of proper cooperation from the client. Even where a fixed or maximum price is agreed, TÜV Rheinland shall be entitled to charge extra fees for such additional expense.

7. Prices

7.1 If the scope of performance is not laid down in writing when the order is placed, invoicing shall be based on costs actually incurred. If no price is agreed in writing, invoicing shall be made in accordance with the price list of TÜV Rheinland valid at the time of performance.

7.2 Unless otherwise agreed, the price shall be payable in advance by the client.

7.3 If the execution of an order extends over more than one month and the value of the contract or the agreed fixed price exceeds €2,500.00 or equivalent value in local currency, TÜV Rheinland may demand payments on account or in instalments.

8. Payment terms

8.1 All invoice amounts shall be due for payment within 30 days of the invoice date without deduction on receipt of the invoice. No discounts and rebates shall be granted.

8.2 Payments shall be made to the bank account of TÜV Rheinland as indicated on the invoice, stating the invoice and client numbers.

8.3 In cases of default of payment, TÜV Rheinland shall be entitled to claim default interest at the applicable short term interest rate publicly announced by a reputable commercial bank in the country where TÜV Rheinland is located. At the same time, TÜV Rheinland reserves the right to claim further damages.

8.4 Should the client default in payment of the invoice despite being granted a reasonable grace period, TÜV Rheinland shall be entitled to cancel the contract, withdraw the certificate, claim damages for non-performance and refuse to continue performance of the contract.

8.5 The provisions set forth in article 8.4 shall also apply in cases involving returned cheques, cessation of payment, commencement of insolvency proceedings against the client's assets or cases in which the commencement of insolvency proceedings has been dismissed due to lack of assets.

8.6 Objections to the invoices of TÜV Rheinland shall be submitted in writing within two weeks of receipt of the invoice.

9. Acceptance of work

9.1 Any part of the work required or which is complete in itself may be presented by TÜV Rheinland for acceptance as an instalment. The client shall be obliged to accept it immediately.

9.2 If acceptance is required contractually agreed in an individual case, this shall be deemed to have taken place two (2) weeks after completion and handover of the work, unless the client refuses acceptance within this period stating at least one fundamental breach of contract by TÜV Rheinland.

9.3 The client is not entitled to refuse acceptance due to insignificant breach of contract by TÜV Rheinland.

9.4 If acceptance is excluded according to the nature of the work performance of TÜV Rheinland, the completion of the work shall take place.

9.5 During the Follow-Up stage, the client was unable to make use of the time windows provided for within the scope of a certification procedure for auditing/performance by TÜV Rheinland and the certificate is therefore to be withdrawn (e.g. performance of surveillance audits), or if the client cancels or postpones a confirmed audit, TÜV Rheinland is entitled to terminate the contract. TÜV Rheinland is entitled to immediately charge a lump-sum compensation of 10% of the order amount as compensation for expenses. The client reserves the right to prove that the TÜV Rheinland has incurred no damage whatsoever or only a considerably lower damage than the above lump sum.

10. Confidentiality

10.1 For the purpose of these terms and conditions, "confidential information" means all know-how, trade secrets, documents, images, drawings, expertise, information, data, test results, reports, samples, project documents, pricing and financial information, customer and supplier information, and marketing technology information transmitted by e-mail. If confidential information is disclosed orally by one Party (the "disclosing party") to the other Party (the "receiving party"), in writing or orally, in printed or electronic form. Confidential information is expressly not the data and know-how or other disclosed information of the disclosing party, but information that is not and proprietary to the client, within the scope of the provision of services by TÜV Rheinland. TÜV Rheinland is entitled to store, use, further develop and pass on the data obtained in connection with the provision of services for the purposes of developing new services, improving services and analysing the provision of services. 10.2 The disclosing party shall mark all confidential information disclosed in written form as confidential before passing it onto the receiving party. The same applies to confidential information transmitted by e-mail. If confidential information is disclosed orally, the receiving party shall be appropriately informed in advance and the disclosing party shall confirm in writing the confidentiality nature of the information within five working days of oral disclosure. Where the disclosing party does not do so in writing within the period, the receiving party shall not take any confidentiality obligations hereunder towards such information. The client shall avoid using any third party platform and/or system (e.g. Wechat, etc.) authorized by TÜV Rheinland to disclose confidential information. The disclosing party shall send any confidential information to company email of TÜV Rheinland employees through its company email. If the client suffers from any losses or damages due to any theft or leakage to be caused by the adoption of the disclosing party's platform, the disclosing party methods mentioned above, TÜV Rheinland shall be waived for any compensation liabilities.

10.3 All confidential information which the disclosing party transmits or otherwise discloses to the receiving party and which is created during performance of the contract shall be confidential information and may only be used by the receiving party for the purposes of performing the contract, unless expressly otherwise agreed in writing by the disclosing party.

10.4 The client may not copy, distribute, publish or otherwise disclose by the receiving party, unless this is necessary for fulfilling the purpose of the contract or TÜV Rheinland is required to pass on confidential information, inspection reports or documentation to the government authorities, public bodies, accreditation bodies or third parties in order to obtain or maintain accreditation. TÜV Rheinland is not responsible for the legal consequences of such disclosures. The disclosing party shall be held liable for any damages caused by the disclosing party to the receiving party. The disclosing party shall be held liable for any damages caused by the disclosing party to the receiving party. The disclosing party shall be held liable for any damages caused by the disclosing party to the receiving party.

11. Transfer of rights of use of the generated work results

11.1 TÜV Rheinland shall retain all exclusive copyrights in the reports, expert reports/opinions, test reports/results, results, calculations, presentations etc. prepared by TÜV Rheinland, unless otherwise agreed by the parties in a separate agreement. As the owner of the copyrights, TÜV Rheinland is free to grant other parties the right to use the work results for individual or all types of use ("right of use").

11.2 The client, as a simple, unlimited, non-transferable, non-sublicensable right of use to the contents of the work results produced within the scope of the contract, unless otherwise agreed by the parties in a separate agreement. The client may only use such reports, expert reports/opinions, test reports/results, calculations, presentations etc. prepared within the scope of the contract for the contractually agreed purpose.

11.3 The transfer of right of use of the generated work results regulated in clause 11.2 of the GTBCB is subject to full payment of the remaining amount of the contract price.

11.4 The client may use work results only complete and unshortened. The client may only pass on the work results in full unless TÜV Rheinland has given its prior written consent to the partial passing on of work results.

11.5 Any publication or duplication of the work results for advertising purposes or any further use of the work results beyond the scope regulated in clause 11.2, and any quotation of the introduction of TÜV Rheinland shall be limited to (i) in the case of a contract with a fixed overall fee, three times the overall fee for the entire contract; (ii) in the case of a contract for an annually recurring services, the agreed annual fee; (iii) in the case of a contract expressly charged on a time and material basis, a maximum of 20,000 Euro or equivalent amount in local currency; and (iv) in the case of a framework agreement that provides for the possibility of placing individual orders, three times of the fee for the individual order under which the damages or losses have occurred. Notwithstanding the above, the client shall be held liable for any damages or losses caused according to the foregoing provisions exceeds 25 Million Euro or equivalent amount in local currency, the total and accumulated liability of TÜV Rheinland shall be only limited to and shall not exceed the said 25 Million Euro or equivalent amount in local currency.

11.6 The limitation of liability according to article 12.1 above shall not apply to damages and/or losses caused by malice, intent or gross negligence on the part of TÜV Rheinland or its vicarious agents. Such limitation shall not apply to damages for a person's death, or injury or illness. In cases involving a fundamental breach of contract, TÜV Rheinland will be liable even where minor negligence is involved. For this purpose, a "fundamental breach" is a breach of a material contractual obligation, the performance of which permits the due performance of the contract. Any claim for damages for a fundamental breach of contract shall be limited to the amount of damages reasonably foreseen as a possible consequence of such breach of contract at the time of the breach (reasonably foreseeable damages), unless any of the circumstances described in article 12.2 applies.

11.7 TÜV Rheinland shall not be liable for the acts of the personnel made available by the client to support TÜV Rheinland in the performance of the contract. The liability of the client for such personnel made available is regarded as vicarious agent of TÜV Rheinland. If TÜV Rheinland is not liable for the acts of the personnel made available by the client under the foregoing provision, the client shall indemnify TÜV Rheinland against any claims made by third parties arising from or in connection with such personnel's acts.

11.8 Unless otherwise contractually agreed in writing, TÜV Rheinland shall only be liable under the contract for damages caused by the personnel made available by the client.

11.9 The limitation periods for claims for damages shall be based on statutory provisions.

11.10 None of the provisions of this article 12 changes the burden of proof to the disadvantage of the client.

12. Liability of TÜV Rheinland

12.1 Irrespective of the legal basis, to the fullest extent permitted by applicable law, in the event of a breach of contractual obligations or tort, the liability of TÜV Rheinland for all damages, losses and reimbursement of expenses caused by TÜV Rheinland, its legal representatives and/or employees shall be limited to: (i) in the case of a contract with a fixed overall fee, three times the overall fee for the entire contract; (ii) in the case of a contract for an annually recurring services, the agreed annual fee; (iii) in the case of a contract expressly charged on a time and material basis, a maximum of 20,000 Euro or equivalent amount in local currency; and (iv) in the case of a framework agreement that provides for the possibility of placing individual orders, three times of the fee for the individual order under which the damages or losses have occurred. Notwithstanding the above, the client shall be held liable for any damages or losses caused according to the foregoing provisions exceeds 25 Million Euro or equivalent amount in local currency, the total and accumulated liability of TÜV Rheinland shall be only limited to and shall not exceed the said 25 Million Euro or equivalent amount in local currency.

12.2 The limitation of liability according to article 12.1 above shall not apply to damages and/or losses caused by malice, intent or gross negligence on the part of TÜV Rheinland or its vicarious agents. Such limitation shall not apply to damages for a person's death, or injury or illness. In cases involving a fundamental breach of contract, TÜV Rheinland will be liable even where minor negligence is involved. For this purpose, a "fundamental breach" is a breach of a material contractual obligation, the performance of which permits the due performance of the contract. Any claim for damages for a fundamental breach of contract shall be limited to the amount of damages reasonably foreseen as a possible consequence of such breach of contract at the time of the breach (reasonably foreseeable damages), unless any of the circumstances described in article 12.2 applies.

12.3 TÜV Rheinland shall not be liable for the acts of the personnel made available by the client to support TÜV Rheinland in the performance of the contract. The liability of the client for such personnel made available is regarded as vicarious agent of TÜV Rheinland. If TÜV Rheinland is not liable for the acts of the personnel made available by the client under the foregoing provision, the client shall indemnify TÜV Rheinland against any claims made by third parties arising from or in connection with such personnel's acts.

12.4 Unless otherwise contractually agreed in writing, TÜV Rheinland shall only be liable under the contract for damages caused by the personnel made available by the client.

12.5 The limitation periods for claims for damages shall be based on statutory provisions.

12.6 None of the provisions of this article 12 changes the burden of proof to the disadvantage of the client.

13. Export control

13.1 When passing on the services provided by TÜV Rheinland or parts thereof to third parties in Greater China or other regions, the client must comply with the respectively applicable regulations of national and international export control law.

13.2 The performance of a contract with the client is subject to the proviso that there are no obstacles to performance due to national or international foreign trade legislations or embargoes and/or

14. Data protection notice

The client understands and agrees that TÜV Rheinland processes personal data (including but not limited to personal information) of the client and its related parties (including but not limited to the supplier of the client) in the context of the performance of this contract. The client confirms that it has obtained the prior consent of the data subject, which entitles TÜV Rheinland to access, use, or process the personal data that the client collected or processed by itself and transferred to TÜV Rheinland. For certain services, TÜV Rheinland may also process personal data of the client. TÜV Rheinland will use and process the data in accordance with the relevant legal basis. If any personal data has been disclosed or transferred to any third party or any overseas party outside of the district in which the personal data was collected, the client also confirms that it has obtained the prior consent of the data subject. TÜV Rheinland will carry out cross-border data transmission and protect the data in compliance with the privacy and personal data security related laws and regulations in China and the local country. TÜV Rheinland will take measures to avoid any leakage, abuse, manipulation, damage or unauthorized access of personal data. The personal data will be deleted immediately as soon as a corresponding reason for deletion arises. Data subjects may exercise the following rights: right of information, right of decision, right of rectification, right of deletion, right of processing limitation, right of objection, right of data transferability. In addition, persons concerned by the data processing have the right to revoke their consent at any time with effect for the future, as well as the right to file a complaint with the competent data protection supervisory authority. For further details on the processing of personal data by TÜV Rheinland as the personal responsible or contract processor, please refer to the respective data protection information. You can contact the Group Data Protection Officer of TÜV Rheinland by e-mail at dataprotection@tuv.com or by post at the following address: TÜV Rheinland AG, c/o Group Data Protection Officer, Am Grauen Stein, 51105 Cologne, Germany.

15. Retention of test material and documentation

15.1 The test samples submitted by the client to TÜV Rheinland for testing will be scrapped following testing or will be returned to the client at the client's expense. The only exceptions are test samples, which are placed in storage on the basis of statutory regulations or of another agreement.

15.2 Charges apply if the test samples are stored at the premises of TÜV Rheinland. The cost of placing a test sample into storage will be disclosed to the client in the quotation.

15.3 The client understands and agrees that TÜV Rheinland may place in storage at their premises, the reference samples or documents must be made available to TÜV Rheinland upon request promptly and free of charge. If the client, in response to such a request, is incapable of making the reference samples or documents available, any liability claims for material and pecuniary damage resulting from the respective testing and certification that is brought forward by the client against TÜV Rheinland shall be voided.

15.4 The client reserves the right to request the return of the test samples after the expiry of the test mark certificates or shall meet the applicable legal requirements for EU/EEC certificates of conformity and GS mark certificates.

15.5 The completed and dispatched of the test samples for storage on the client's premises are borne by the client. TÜV Rheinland will be liable for the loss of test samples or reference samples from the laboratories or warehouses of TÜV Rheinland only in case of gross negligence.

16. Termination of the contract

16.1 Notwithstanding clause 3.3 of the GTBCB, TÜV Rheinland and the client are entitled to terminate the contract in its entirety or, in the case of services, terminated in one contract each of the combined parts of the contract individually and independently of the continuation of the remaining services with six (6) months' notice to the end of the contractually agreed term. The notice period shall be shortened to six (6) weeks in case TÜV Rheinland is prevented from performing the services due to a loss or suspension of its accreditation or notification.

16.2 For good cause, TÜV Rheinland may consider giving a written notice to the client to terminate the contract without being bound by any liabilities and/or claims for relevant service fees (any services provided by TÜV Rheinland due to the termination date of the contract. The aforesaid good causes includes but not limited to the following:

- a) the client does not fulfil its obligations to TÜV Rheinland, in particular if the client repeatedly fails to comply with the conditions in the conditions which are relevant for certification or signs of such changes;
- b) the client misuses the certificate or certification mark or uses it in violation of the contract;
- c) the event of several consecutive delays in the registration of the relevant service fees;
- d) a substantial deterioration of the financial circumstances of the client occurs and as a result the payment claims of TÜV Rheinland under the contract are considerably endangered and TÜV Rheinland cannot reasonably be expected to continue the contractual relationship;
- e) in the event of any serious misrepresentation, be it by intentional fraud or grossly negligent behavior of the managers, employees or agents of the client;
- f) if TÜV Rheinland, in accordance with the contract, is prevented from continuing or finalizing the performance of the service, e.g. in case of force majeure, government interference, sanctions, loss of accreditation or notification; or other.

16.3 If the country/region where the registration of the relevant service project in the contract does not belong to the insurance coverage applicable to TÜV Rheinland, and TÜV Rheinland believes that there is a risk or some risks beyond its control to continue to perform the contract, the client is obliged to terminate the contract with written notice to TÜV Rheinland for good cause. TÜV Rheinland shall be entitled to a lump-sum claim for damages against the client if the conditions of the contract for damages exist. In this case, the client shall owe 15% of the remuneration to be paid until the end of the fixed contract term. The client is obliged to terminate the contract with written notice if there is no damage or a considerably lower damage, TÜV Rheinland reserves the right to prove a considerably higher damage in individual cases.

16.4 TÜV Rheinland is entitled to terminate the contract with written notice if the client has not been able to make use of the time windows for auditing /service provision provided by TÜV Rheinland within the scope of a certification procedure and the certificate therefore has to be withdrawn (for example during the performance of monitoring audits). Clause 16.3 applies accordingly.

17. Force Majeure

17.1 "Force Majeure" means the occurrence of an event or circumstance that prevents or impedes a Party from performing one or more of its contractual obligations under the contract, if and to the extent that that Party proves: (a) that such impediment is beyond its reasonable control; and (b) that it could not reasonably have avoided or overcome the event; and (c) that the effects of the impediment could not reasonably have been avoided or overcome by the affected Party.

17.2 In the absence of proof to the contrary, the following events affecting a Party shall be presumed to fulfil conditions (a) and (b) under paragraph 1.1 of this Clause: (i) war (whether declared or not), hostilities, invasion, act of foreign enemies, extensive military mobilization; (ii) civil war, riot, rebellion and revolution; (iii) strikes or lockouts; (iv) acts of terrorism, sabotage or piracy; (v) currency and trade restriction, embargo, sanction; (vi) act of authority whether lawful or unlawful, compliance with any law or governmental order, expropriation, seizure of works, requisition, nationalization; (v) plague, epidemic, natural disaster or extreme natural event; (vii) explosion, fire, destruction of equipment, prolonged break-down of transport, telecommunication, information system or energy; (viii) general labor disturbance such as boycott, strike and lock-out; (ix) slow-occupation of territories and premises.

17.3 The Party successfully invoking this Clause is relieved from its duty to perform its obligations under the contract from any liability in damages or from any other contractual remedy for breach of contract, from the time at which the impediment causes inability to perform, provided that the notice thereof is given without delay. If notice thereof is not given without delay, the relief is effective from the time at which notice thereof reaches the other Party. Where the effect of the impediment or event invoked is temporary, the above consequences shall apply only as long as the impediment invoked impedes performance of the affected Party. Where the duration of the impediment invoked has the effect of substantially depriving the contracting Parties of what they were reasonably entitled to expect under the contract, the affected Party has the right to terminate the contract by notification within a reasonable period to the other Party. Unless otherwise agreed, the Parties expressly agree that the contract may be terminated by either Party if the duration of the impediment exceeds 120 days.

18. Hardship

18.1 The Parties are bound to perform their contractual duties even if events have rendered performance more onerous than could reasonably have been anticipated at the time of the conclusion of the contract.

18.2 Notwithstanding paragraph 1 of this Clause, where a Party proves that:

- (a) the continued performance of its contractual duties has become excessively onerous due to an event beyond its reasonable control which it could not reasonably have been expected to have taken into account at the time of the conclusion of the contract; and that
- (b) it could not reasonably have avoided or overcome the event or its consequences, the Parties are bound, within a reasonable time of the invocation of this Clause, to negotiate alternative contractual terms which reasonably allow to overcome the consequences of the event.

18.3 Where Clause 18.2 applies, but where the Parties have been unable to agree alternative contractual terms as provided in that paragraph, the Party invoking this Clause is entitled to terminate the contract, but cannot request adaptation by the judge or arbitrator without the agreement of the other Party.

19. Partial invalidity, written form, place of jurisdiction and dispute resolution

19.1 All amendments and supplements must be in writing in order to be effective. This also applies to amendments and supplements to this clause 17.1.

19.2 Should one or several of the provisions under the contract and/or these terms and conditions be or become ineffective, the contracting parties shall replace the invalid provision with a legally valid provision that comes closest to the content of the invalid provision in legal and commercial terms.

19.3 Unless otherwise stipulated in the contract, the governing law of the contract and these terms and conditions shall be the law of the country in which the contract is concluded.

19.4 If TÜV Rheinland in question is legally registered and existing in the People's Republic of China, the contracting parties hereby agree that the contract and these terms and conditions shall be governed by the law of the People's Republic of China.

19.5 If TÜV Rheinland in question is legally registered and existing in Taiwan, the contracting parties hereby agree that the contract and these terms and conditions shall be governed by the laws of Taiwan.

19.6 If TÜV Rheinland in question is legally registered and existing in Hong Kong, the contracting parties hereby agree that the contract and these terms and conditions shall be governed by the laws of Hong Kong.

19.7 Any dispute in connection with the contract and these terms and conditions or the execution thereof shall be settled friendly through negotiations.

19.8 Unless otherwise stipulated in the contract, no arbitration or no agreement in respect of the extension of the negotiation period can be reached within two months of the arising of the dispute, the dispute shall be submitted:

- (a) in the case of TÜV Rheinland in question being legally registered and existing in the People's Republic of China, to China International Economic and Trade Arbitration Commission (CIETAC) to be settled by arbitration under the Arbitration Rules of CIETAC in force when the arbitration is submitted. The arbitration shall take place in Beijing, Shanghai, Shenzhen or Chongqing as appropriately chosen by the claiming party;
- (b) in the case of TÜV Rheinland in question being legally registered and existing in Taiwan, to Chinese Arbitration Association (CAA) to be settled by arbitration in accordance with its then current Rules of Arbitration. The arbitration shall take place in Taipei;
- (c) in the case of TÜV Rheinland being legally registered and existing in Hong Kong, to Hong Kong International Arbitration Centre (HKIAC) to be settled by arbitration in accordance with its then current Administered Arbitration Rules in force when the Notice of Arbitration is submitted in accordance with these rules. The arbitration shall take place in Hong Kong.

19.9 The decision of the arbitration tribunal shall be final and binding on both parties. The arbitration fee shall be borne by the losing party.

20. Partial invalidity, written form, place of jurisdiction and dispute resolution

20.1 All amendments and supplements must be in writing in order to be effective. This also applies to amendments and supplements to this clause 17.1.

20.2 Should one or several of the provisions under the contract and/or these terms and conditions be or become ineffective, the contracting parties shall replace the invalid provision with a legally valid provision that comes closest to the content of the invalid provision in legal and commercial terms.

20.3 Unless otherwise stipulated in the contract, the governing law of the contract and these terms and conditions shall be the law of the country in which the contract is concluded.

20.4 If TÜV Rheinland in question is legally registered and existing in the People's Republic of China, the contracting parties hereby agree that the contract and these terms and conditions shall be governed by the law of the People's Republic of China.

20.5 If TÜV Rheinland in question is legally registered and existing in Taiwan, the contracting parties hereby agree that the contract and these terms and conditions shall be governed by the laws of Taiwan.

20.6 If TÜV Rheinland in question is legally registered and existing in Hong Kong, the contracting parties hereby agree that the contract and these terms and conditions shall be governed by the laws of Hong Kong.

20.7 Any dispute in connection with the contract and these terms and conditions or the execution thereof shall be settled friendly through negotiations.

20.8 Unless otherwise stipulated in the contract, no arbitration or no agreement in respect of the extension of the negotiation period can be reached within two months of the arising of the dispute, the dispute shall be submitted:

- (a) in the case of TÜV Rheinland in question being legally registered and existing in the People's Republic of China, to China International Economic and Trade Arbitration Commission (CIETAC) to be settled by arbitration under the Arbitration Rules of CIETAC in force when the arbitration is submitted. The arbitration shall take place in Beijing, Shanghai, Shenzhen or Chongqing as appropriately chosen by the claiming party;
- (b) in the case of TÜV Rheinland in question being legally registered and existing in Taiwan, to Chinese Arbitration Association (CAA) to be settled by arbitration in accordance with its then current Rules of Arbitration. The arbitration shall take place in Taipei;
- (c) in the case of TÜV Rheinland being legally registered and existing in Hong Kong, to Hong Kong International Arbitration Centre (HKIAC) to be settled by arbitration in accordance with its then current Administered Arbitration Rules in force when the Notice of Arbitration is submitted in accordance with these rules. The arbitration shall take place in Hong Kong.

20.9 The decision of the arbitration tribunal shall be final and binding on both parties. The arbitration fee shall be borne by the losing party.

21. Partial invalidity, written form, place of jurisdiction and dispute resolution

21.1 All amendments and supplements must be in writing in order to be effective. This also applies to amendments and supplements to this clause 17.1.

21.2 Should one or several of the provisions under the contract and/or these terms and conditions be or become ineffective, the contracting parties shall replace the invalid provision with a legally valid provision that comes closest to the content of the invalid provision in legal and commercial terms.

21.3 Unless otherwise stipulated in the contract, the governing law of the contract and these terms and conditions shall be the law of the country in which the contract is concluded.

21.4 If TÜV Rheinland in question is legally registered and existing in the People's Republic of China, the contracting parties hereby agree that the contract and these terms and conditions shall be governed by the law of the People's Republic of China.

21.5 If TÜV Rheinland in question is legally registered and existing in Taiwan, the contracting parties hereby agree that the contract and these terms and conditions shall be governed by the laws of Taiwan.

21.6 If TÜV Rheinland in question is legally registered and existing in Hong Kong, the contracting parties hereby agree that the contract and these terms and conditions shall be governed by the laws of Hong Kong.

21.7 Any dispute in connection with the contract and these terms and conditions or the execution thereof shall be settled friendly through negotiations.

21.8 Unless otherwise stipulated in the contract, no arbitration or no agreement in respect of the extension of the negotiation period can be reached within two months of the arising of the dispute, the dispute shall be submitted:

- (a) in the case of TÜV Rheinland in question being legally registered and existing in the People's Republic of China, to China International Economic and Trade Arbitration Commission (CIETAC) to be settled by arbitration under the Arbitration Rules of CIETAC in force when the arbitration is submitted. The arbitration shall take place in Beijing, Shanghai, Shenzhen or Chongqing as appropriately chosen by the claiming party;
- (b) in the case of TÜV Rheinland in question being legally registered and existing in Taiwan, to Chinese Arbitration Association (CAA) to be settled by arbitration in accordance with its then current Rules of Arbitration. The arbitration shall take place in Taipei;
- (c) in the case of TÜV Rheinland being legally registered and existing in Hong Kong, to Hong Kong International Arbitration Centre (HKIAC) to be settled by arbitration in accordance with its then current Administered Arbitration Rules in force when the Notice of Arbitration is submitted in accordance with these rules. The arbitration shall take place in Hong Kong.

21.9 The decision of the arbitration tribunal shall be final and binding on both parties. The arbitration fee shall be borne by the losing party.

22. Partial invalidity, written form, place of jurisdiction and dispute resolution

22.1 All amendments and supplements must be in writing in order to be effective. This also applies to amendments and supplements to this clause 17.1.

22.2 Should one or several of the provisions under the contract and/or these terms and conditions be or become ineffective, the contracting parties shall replace the invalid provision with a legally valid provision that comes closest to the content of the invalid provision in legal and commercial terms.

22.3 Unless otherwise stipulated in the contract, the governing law of the contract and these terms and conditions shall be the law of the country in which the contract is concluded.

22.4 If TÜV Rheinland in question is legally registered and existing in the People's Republic of China, the contracting parties hereby agree that the contract and these terms and conditions shall be governed by the law of the People's Republic of China.

22.5 If TÜV Rheinland in question is legally registered and existing in Taiwan, the contracting parties hereby agree that the contract and these terms and conditions shall be governed by the laws of Taiwan.

Product: Li-ion Battery pack

Type Designation: E36100B-ST1



Picture 1 Front View of battery



Picture 2 Rear View of battery

Product: Li-ion Battery pack

Type Designation: E36100B-ST1



Picture 3 Bottom View of battery

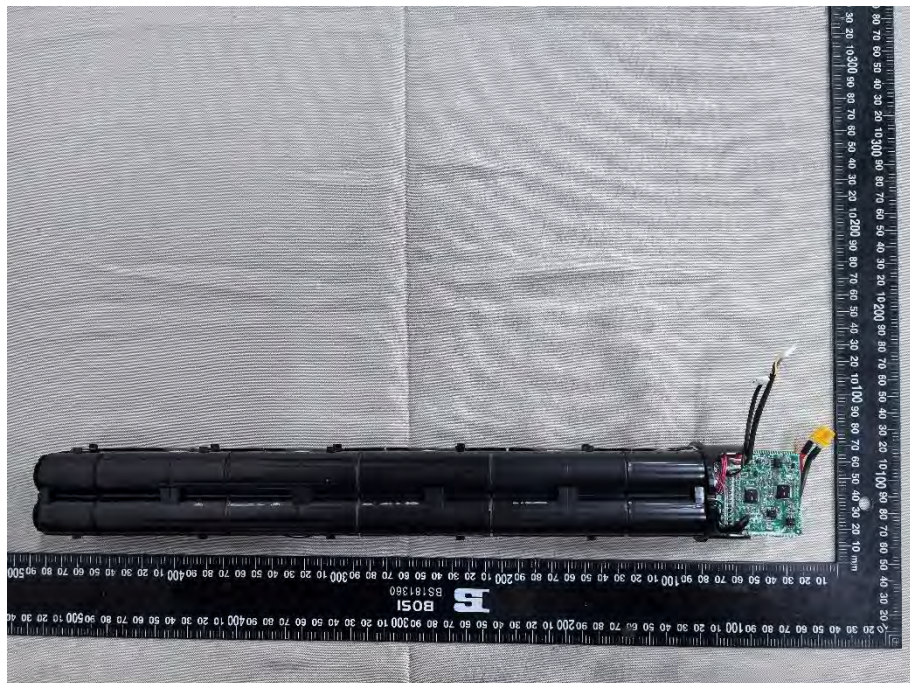

Picture 4 Internal View-1 of battery

Product: Li-ion Battery pack

Type Designation: E36100B-ST1

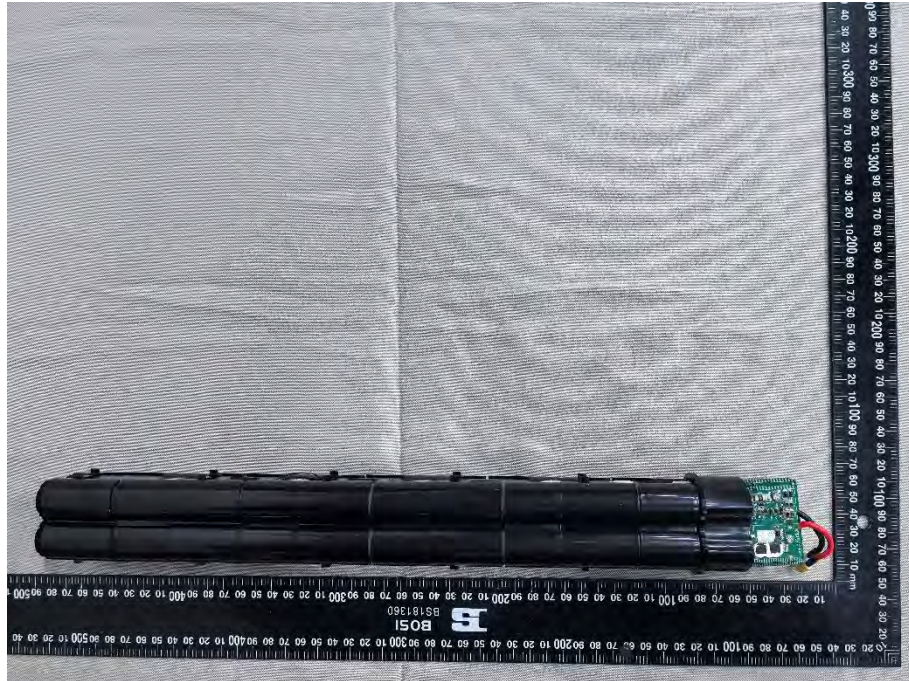

Picture 5 Internal View-2 of battery

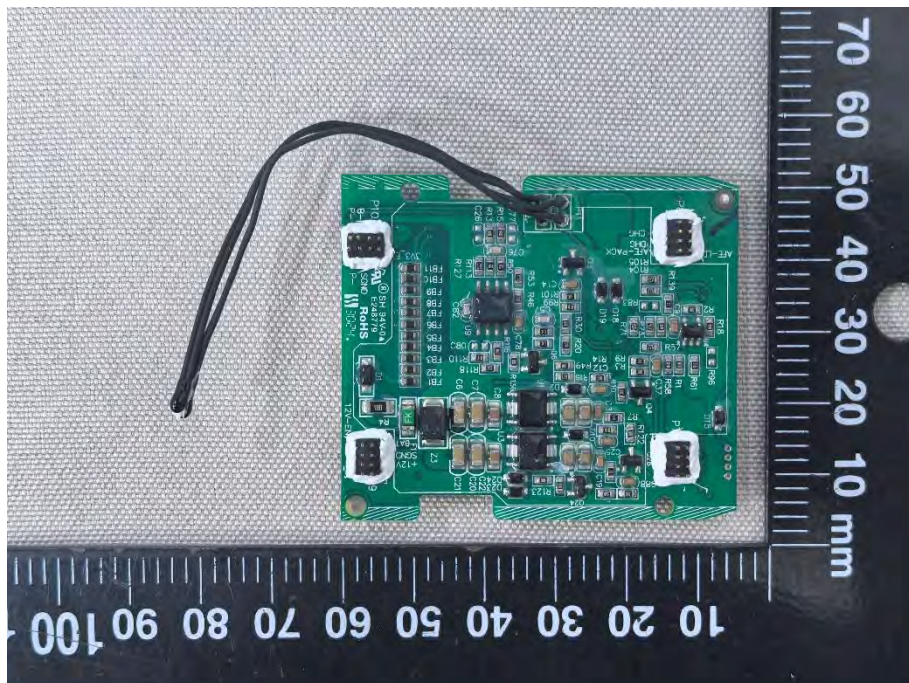

Picture 6 Front View of PCM A

Product: Li-ion Battery pack

Type Designation: E36100B-ST1

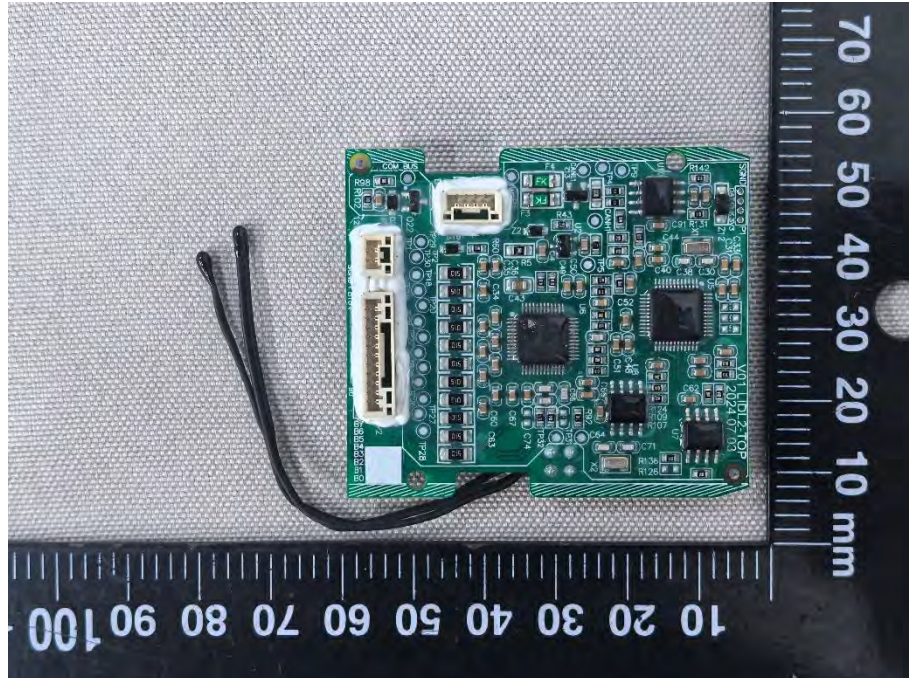

Picture 7 Rear View of PCM A

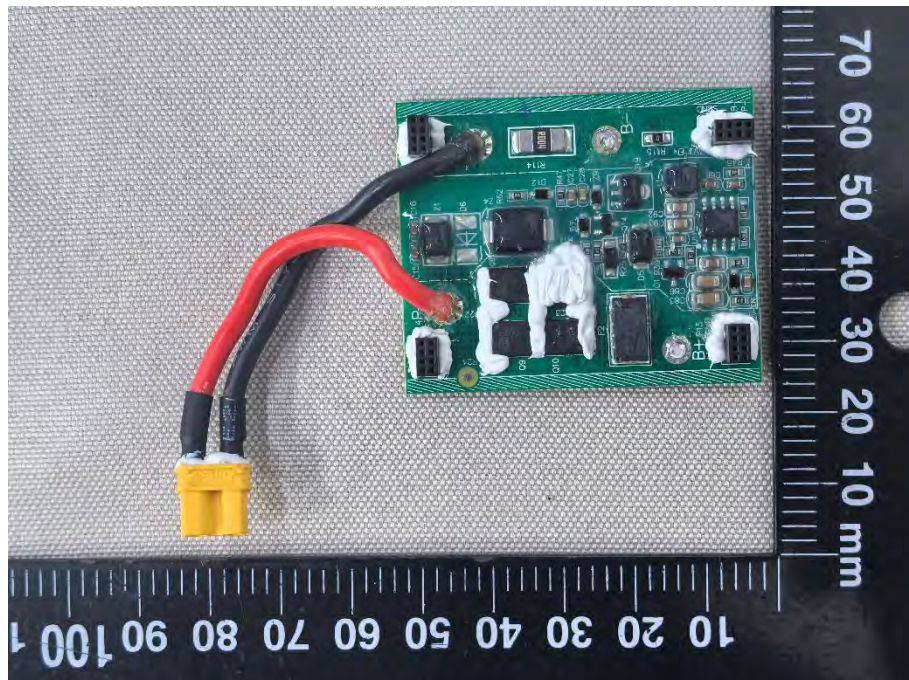

Picture 8 Front View of PCM B

Product: Li-ion Battery pack

Type Designation: E36100B-ST1

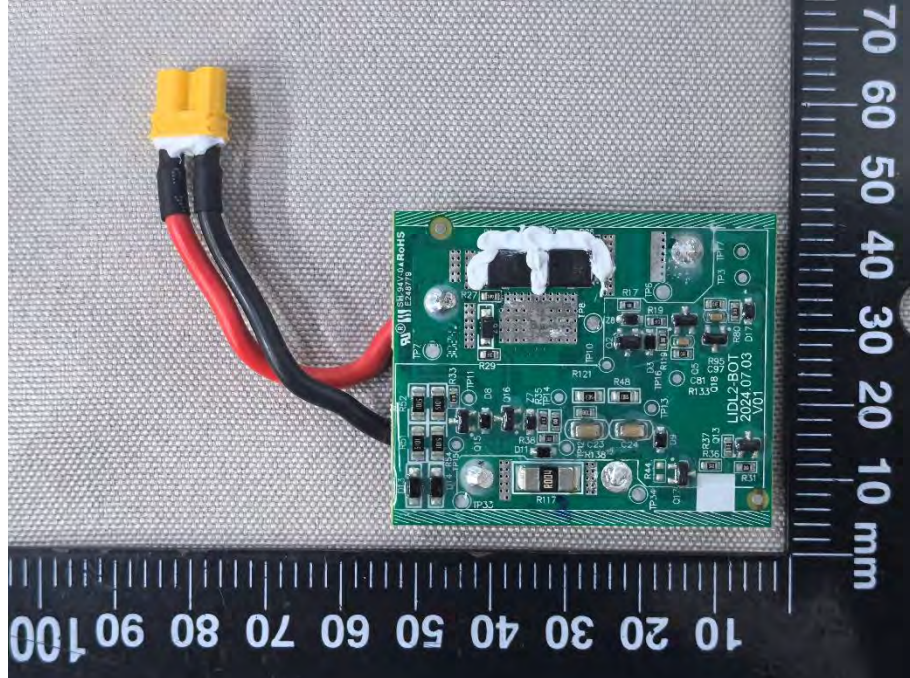

Picture 9 Rear View of PCM B



Picture 10 Front view of the component cell

Product: Li-ion Battery pack

Type Designation: E36100B-ST1

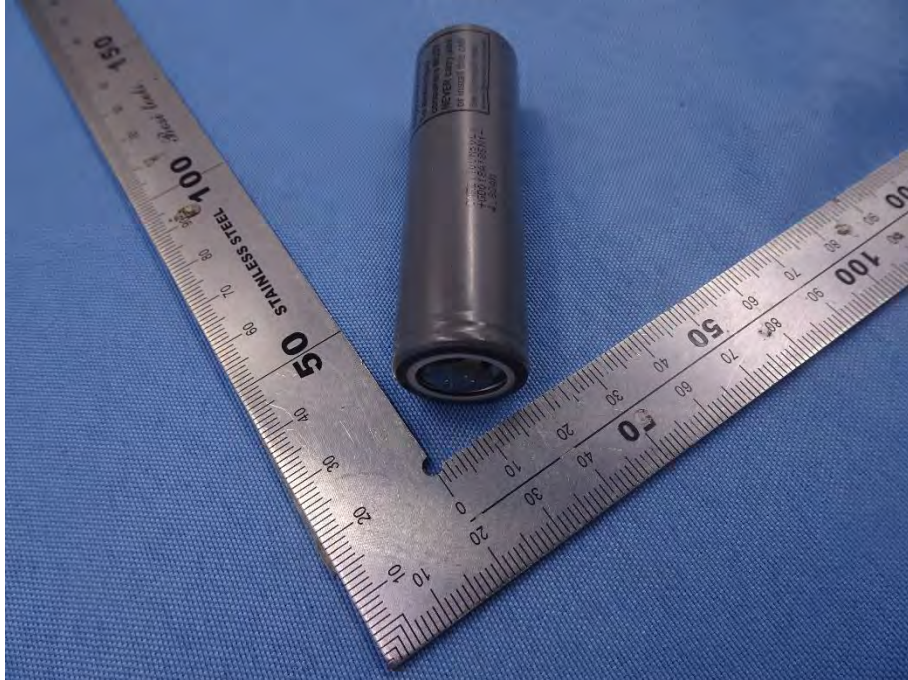

Picture 11 Top view of the component cell

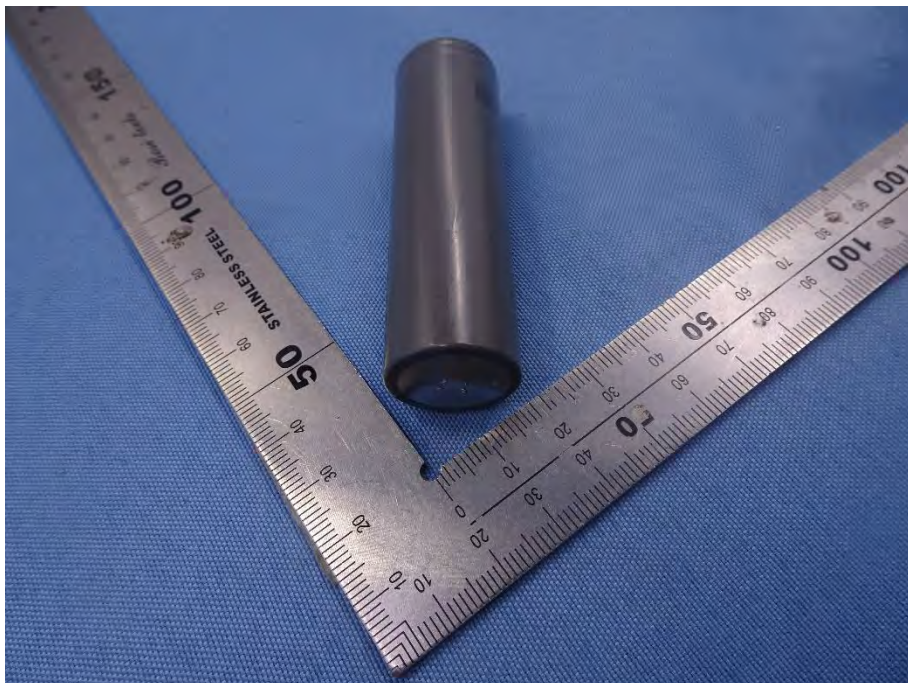

Picture 12 Bottom view of the component cell

Prüfbericht-Nr.: <i>Test report no.:</i>	CN24G9CQ 001	Auftrags-Nr.: <i>Order no.:</i>	168497397	Seite 1 von 26 Page 1 of 26
Kunden-Referenz-Nr.: <i>Client reference no.:</i>	2248221	Auftragsdatum: <i>Order date:</i>	2024-06-26	
Auftraggeber: <i>Client:</i>	Shenzhen Topband Co., Ltd 1F, the Second Phase of Topband Industrial Park, No.2 Sci-Tech Road, Tangtou Community, Shiyan Street, Baoan District, Shenzhen, China			
Prüfgegenstand: <i>Test item:</i>	Rechargeable Li-ion Battery System			
Bezeichnung / Typ-Nr.: <i>Identification / Type no.:</i>	E36100E-ST3,E36100B-ST1,E36200L-IT3A1, E36150A-AL3			
Auftrags-Inhalt: <i>Order content:</i>	Electrical safety testing			
Prüfgrundlage: <i>Test specification:</i>	ISO 13849-1:2023 Safety of machinery — Safety-related parts of control systems — Part 1:General principles for design			
Wareneingangsdatum: <i>Date of sample receipt:</i>	2024-08-10			
Prüfmuster-Nr.: <i>Test sample no.:</i>	A003857189-001 A003857189-002 A003857189-003 A003857189-004			
Prüfzeitraum: <i>Testing period:</i>	2024-08-10 - 2024-9-20			
Ort der Prüfung: <i>Place of testing:</i>	TÜV Rheinland (Shenzhen) Co., Ltd.			
Prüflaboratorium: <i>Testing laboratory:</i>	TÜV Rheinland (Shenzhen) Co., Ltd.			
Prüfergebnis*: <i>Test result*:</i>	Pass			
geprüft von: <i>created by:</i>	 Xun Yu	genehmigt von: <i>authorized by:</i>	 Andy Chen	
Datum: <i>Date:</i>	2024-11-21	Ausstellungsdatum: <i>Issue date:</i>	2024-11-21	
Stellung / Position:	Sachverständige(r)/Expert	Stellung / Position:	Sachverständige(r)/Expert	
Sonstiges / <i>Other:</i>	Attachment 1: Photo documentation (10 pages) This report does not evidence compliance of the provided sample with the relevant standards but only with the referred tests. This test report documents the findings of examination conducted on the delivered product mentioned above only. This report does not entitle the applicant to carry any safety mark on this or similar products. Further for sales or other application purposes of the tested product, any reference to TÜV Rheinland or a test through TÜV Rheinland is only permissible with prior written consent of TÜV Rheinland.			
Zustand des Prüfgegenstandes bei Anlieferung: <i>Condition of the test item at delivery:</i>	Prüfmuster vollständig und unbeschädigt <i>Test item complete and undamaged</i>			
* Legende:	P(ass) = entspricht o.g. Prüfgrundlage(n)	F(ail) = entspricht nicht o.g. Prüfgrundlage(n)	N/A = nicht anwendbar	N/T = nicht getestet
* Legend:	P(ass) = passed a.m. test specification(s)	F(ail) = failed a.m. test specification(s)	N/A = not applicable	N/T = not tested
Dieser Prüfbericht bezieht sich nur auf das o.g. Prüfmuster und darf ohne Genehmigung der Prüfstelle nicht auszugsweise vervielfältigt werden. Dieser Bericht berechtigt nicht zur Verwendung eines Prüfzeichens. <i>This test report only relates to the above mentioned test sample. Without permission of the test center this test report is not permitted to be duplicated in extracts. This test report does not entitle to carry any test mark.</i>				

Prüfbericht-Nr.: CN24G9CQ 001

Seite 2 von 26

Page 2 of 26

Test report no.:

Anmerkungen
Remarks

- | | |
|---|--|
| 1 | <p>Alle eingesetzten Prüfmittel waren zum angegebenen Prüfzeitraum gemäß eines festgelegten Kalibrierungsprogramms unseres Prüfhauses kalibriert. Sie entsprechen den in den Prüfprogrammen hinterlegten Anforderungen. Die Rückverfolgbarkeit der eingesetzten Prüfmittel ist durch die Einhaltung der Regelungen unseres Managementsystems gegeben.
Detaillierte Informationen bezüglich Prüfkonditionen, Prüfequipment und Messunsicherheiten sind im Prüflabor vorhanden und können auf Wunsch bereitgestellt werden.</p> <p><i>The equipment used during the specified testing period was calibrated according to our test laboratory calibration program. The equipment fulfils the requirements included in the relevant standards. The traceability of the test equipment used is ensured by compliance with the regulations of our management system. Detailed information regarding test conditions, equipment and measurement uncertainty is available in the test laboratory and could be provided on request.</i></p> |
| 2 | <p>Wie vertraglich vereinbart, wurde dieses Dokument nur digital unterzeichnet. Der TÜV Rheinland hat nicht überprüft, welche rechtlichen oder sonstigen diesbezüglichen Anforderungen für dieses Dokument gelten. Diese Überprüfung liegt in der Verantwortung des Benutzers dieses Dokuments. Auf Verlangen des Kunden kann der TÜV Rheinland die Gültigkeit der digitalen Signatur durch ein gesondertes Dokument bestätigen. Diese Anfrage ist an unseren Vertrieb zu richten. Eine Umweltgebühr für einen solchen zusätzlichen Service wird erhoben. Informationen zur Verifizierung der Authentizität unserer Dokumente erhalten Sie auf folgender Webseite: go.tuv.com/digital-signature</p> <p><i>As contractually agreed, this document has been signed digitally only. TUV Rheinland has not verified and unable to verify which legal or other pertaining requirements are applicable for this document. Such verification is within the responsibility of the user of this document. Upon request by its client, TUV Rheinland can confirm the validity of the digital signature by a separate document. Such request shall be addressed to our Sales department. An environmental fee for such additional service will be charged. For information on verifying the authenticity of our documents, please visit the following website: go.tuv.com/digital-signature</i></p> |
| 3 | <p>Prüfklausel mit der Note * wurden an qualifizierte Unterauftragnehmer vergeben und sind unter der jeweiligen Prüfklausel des Berichts beschrieben.
Abweichungen von Prüfspezifikation(en) oder Kundenanforderungen sind in der jeweiligen Prüfklausel im Bericht aufgeführt.</p> <p><i>Test clauses with remark of * are subcontracted to qualified subcontractors and described under the respective test clause in the report.
Deviations of testing specification(s) or customer requirements are listed in specific test clause in the report.</i></p> |
| 4 | <p>Die Entscheidungsregel für Konformitätserklärungen basierend auf numerischen Messergebnissen in diesem Prüfbericht basiert auf der "Null-Grenzwert-Regel" und der "Einfachen Akzeptanz" gemäß ILAC G8:2019 und IEC Guide 115:2021, es sei denn, in der auf Seite 1 dieses Berichts genannten angewandten Norm ist etwas anderes festgelegt oder vom Kunden gewünscht. Dies bedeutet, dass die Messunsicherheit nicht berücksichtigt wird und daher auch nicht im Prüfbericht angegeben wird. Zu weiteren Informationen bezüglich des Risikos durch diese Entscheidungsregel siehe ILAC G8:2019.</p> <p><i>The decision rule for statements of conformity, based on numerical measurement results, in this test report is based on the "Zero Guard Band Rule" and "Simple Acceptance" in accordance with ILAC G8:2019 and IEC Guide 115:2021, unless otherwise specified in the applied standard mentioned on Page 1 of this report or requested by the customer. This means that measurement uncertainty is not taken in account and hence also not declared in the test report. For additional information to the resulting risk based of this decision rule please refer to ILAC G8:2019.</i></p> |

This report is the technical evaluation of the battery management system safety related functions according to the requirements in ISO 13849-1:2023.

Production information:

Model No.:

The Rechargeable Li-ion Battery pack E36100E-ST3, E36100B-ST1, E36200L-IT3A1, E36150A-AL3 are specially used as energy system for light electric vehicle (Removable EESS). It consists of several cells and is integrated with the active protective device and passive protective device, which is intended to protect battery against abnormal operations.

Table 1 Key parameters of Models

Product list	E36100E-ST3	E36100B-ST1	E36200L-IT3A1	E36150A-AL3
Model of cell	INR21700M50LT			
Group approach	10S2P	10S2P	10S4P	10S3P
Model Spec	36.9V,9.6Ah	36.9V,10Ah	36.9V,19.2Ah	36.9V,14.7Ah
Voltage range	28-42V	28-42V	28-42V	28-42V
Max. continuous charge current (A)	2.88A(0-10°C) 4A (10-35°C) 3A (35-40°C)	2.88A(0-10°C) 4A (10-35°C) 3A (35-40°C)	4A (0-40°C)	4A (0-40°C)
Max. continuous discharge current (A)	4.8A(-20-10°C) 15A (10-30°C) 10A (35-50°C)	4.8A(-20-10°C) 15A (10-30°C) 10A (35-50°C)	9.6A(-20-10°C) 15A (10-30°C) 12A (35-50°C)	7.2A(-20-10°C) 15A (10-30°C) 12A (35-50°C)
Charging temperature Range	0 ~ 40°C			
Discharging temperature Range	-20 ~ 50°C			

NOTE: BMS and setting limits of safety parameters used in models are same. For compatibility, take the 10P2S's current limit as the current protection threshold. So E36100E-ST3 was evaluated as representative of other products.

Conclusion:

The safety function of over/under voltage, over charging current, over discharging current, high/low temperature protection for Battery Management Systems could be used in PLC applications.

SF Description:**SF01: Safety function of voltage control PLr = C**

Over voltage protection 1: cell voltage is higher than 4.2V (response time: 2S), switch off CMOS and warning

Over voltage protection 2: cell voltage is higher than 4.25V (response time: 2S), switch off CMOS and warning

Under voltage protection 1: cell voltage is lower than 2.8V (response time: 2S), switch off DMOS and warning

Under voltage protection 2: cell voltage is lower than 2.0V (response time: 2S), switch off DMOS and warning

SF02: Safety function of current control PLr = C**Charging:**

Over current protection 1: When cell temperature is between 0~10°C, charging current is larger than 2.8A (response time: 4S), switch off CMOS and warning; When cell temperature is higher than 10°C, charging current is larger than 4.5A (response time: 4S), switch off CMOS and warning

Over current protection 2: Charging current is larger than 10A (response time: 400mS), switch off CMOS and warning

Discharging:

Over current protection 1: Discharging current is larger than 18A (response time: 4S), switch off DMOS and warning

Over current protection 2: Discharging current is larger than 20A (response time: 2S), switch off DMOS and warning

SF03: Safety function of temperature control PLr = C**Charging:**

High temperature protection: Cell temperature is higher than 45°C (response time: 5S), switch off CMOS and warning

Low temperature protection: Cell temperature is lower than 0°C (response time: 5S), switch off CMOS and warning

Discharging:

High temperature protection: Cell temperature is higher than 55°C (response time: 5S), switch off DMOS and warning

Low temperature protection: Cell temperature is lower than -20°C (response time: 5S), switch off DMOS and warning

Product Outline:

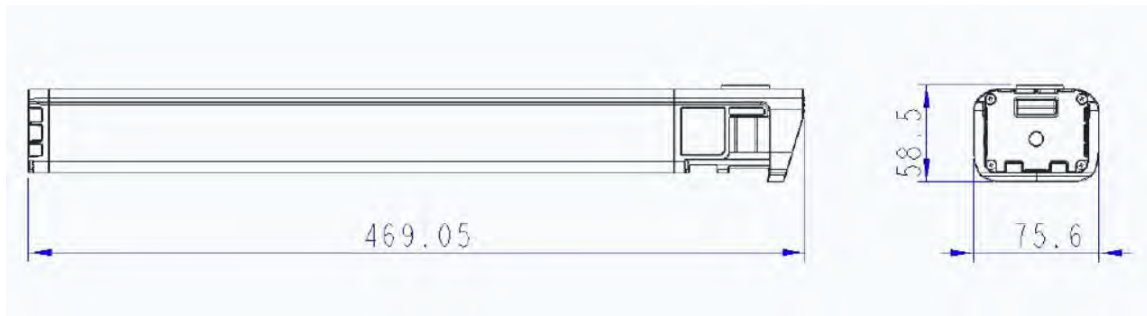

Figure 1 Product Outline (E36100E-ST3)

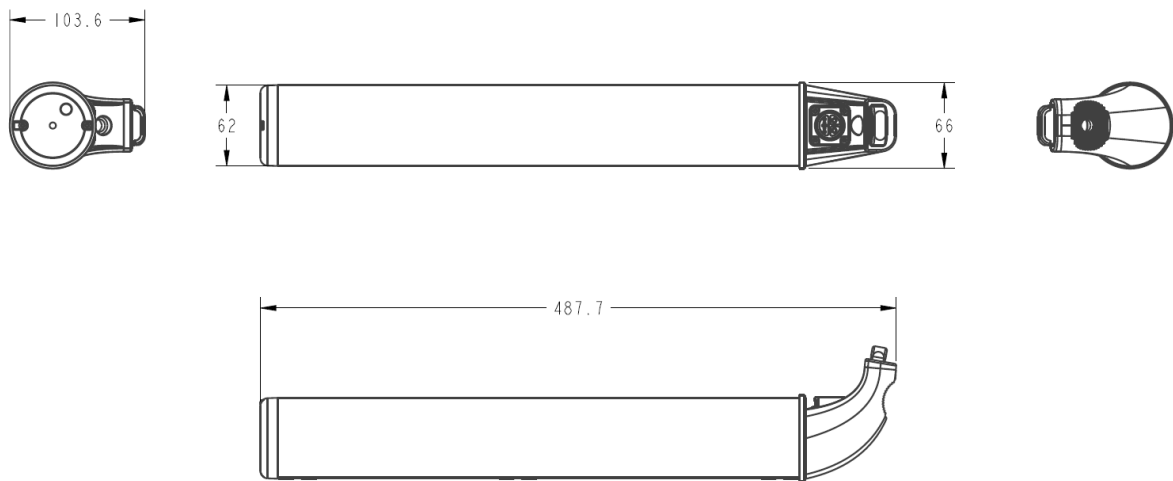

Figure 2 Product Outline(E36100B-ST1)

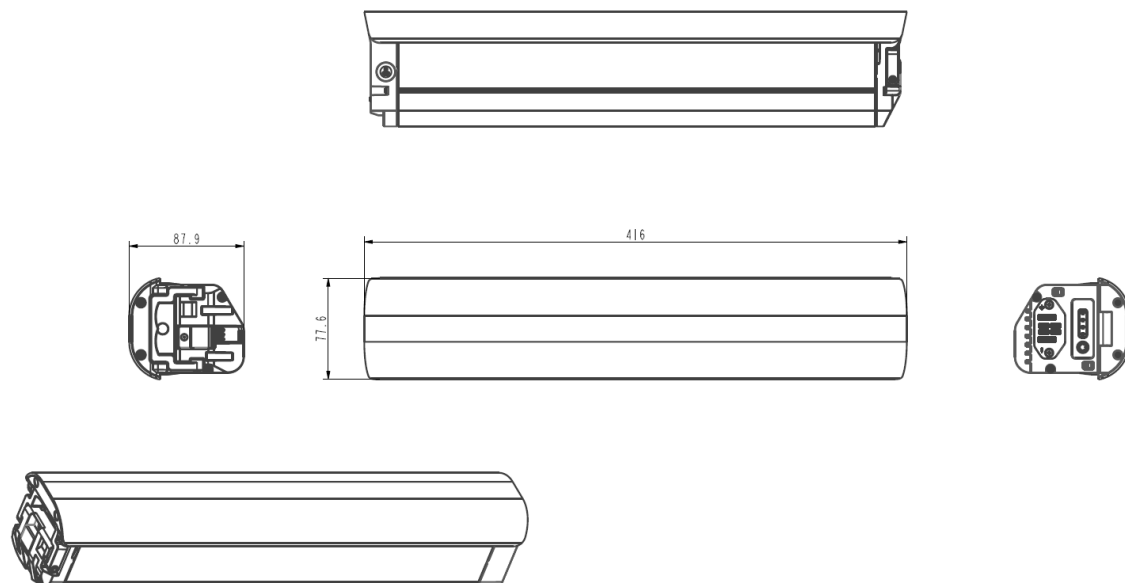

Figure 3 Product Outline (E36200L-IT3A1)

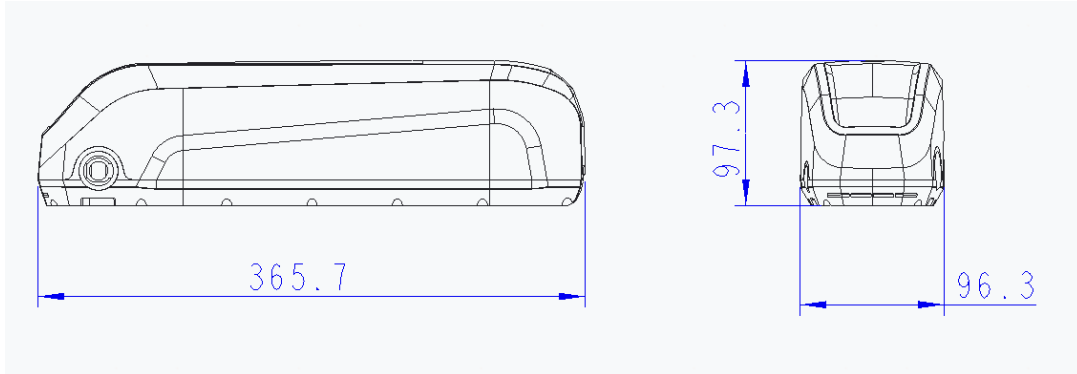

Figure 4 Product Outline (E36150A-AL3)

Cell characteristics:

Item	Condition / Note	Specification
2.1 Energy ¹⁾	Standard charge/discharge * 1C=4800mA Charge (CC-CV) : 0.3C (1,440mA), 4.20V, 50mA cut off, Charging time ³⁾ 4.5h (one complete charge ²⁾) at 25°C Discharge (CC) : 0.2C (960mA), 2.5V cut off at 25°C	Nom. 18.2 Wh Min. 17.6 Wh
2.2 Nominal Voltage	Average by Standard charge/discharge	3.69 V
2.3 Shipping Cell Voltage	State Of Charge ("SOC")	Below SOC 30%
2.4 Charge voltage ¹⁾	2.1 Capacity measurement SOC Usable cycle SOC (in field use) In all measurements and operations of the Cell, the maximum closed circuit voltage shall not exceed the following value	4.20V Refer to 4.2.4
2.5.1 Max. Charge Current ⁴⁾ (complete full charge) ²⁾ (Atmosphere Temperature)	0 ~ 10 °C	0.3C (1,440mA)
	10 ~ 25 °C	0.5C (2,400mA)
	25 ~ 45 °C	0.7C (3,360mA)
2.5.2 Max. Charge Current ⁴⁾ (complete full charge) ²⁾ (Cell surface Temperature)	0 ~ 10 °C	0.3C (1,440mA)
	10 ~ 25 °C	0.5C (2,400mA)
	25 ~ 55 °C	0.7C (3,360mA)
2.6 Discharge cut off voltage ¹⁾	2.1 Capacity measurement SOC Usable cycle SOC (in field use) In all measurements and operations of the Cell, the minimum closed circuit voltage shall not drop below the following value	2.50V Refer to 4.2.4
2.7.1 Max. Discharge Current ⁴⁾ (complete full discharge) ²⁾ (Atmosphere Temperature)	-30 ~ -20 °C	0.3C (1,440mA)
	-20 ~ 10 °C	2.0C (9,600 mA)
	10 ~ 25 °C	3.0C (14,400 mA)
	25 ~ 55 °C	2.0C (9,600 mA)

2.7.2 Max. Discharge Current ⁴⁾ (complete full discharge) ²⁾ (Cell surface Temperature)	-30 ~ -20 °C	0.3C (1,440mA)
	-20 ~ 10 °C	2.0C (9,600 mA)
	10 ~ 25 °C	3.0C (14,400 mA)
	25 ~ 70 °C	2.0C (9,600 mA)
2.8 Safety Over Voltage (Permanent Failure)	Cell voltage including tolerance shall not exceed the 4.25V to prevent any safety events. And cell performance can't be guaranteed between 4.20V and 4.25V	Max 4.25V (Refer to 6.2)
2.9 Safety Under Voltage (Permanent Failure)	Cell voltage including tolerance shall not drop below the 2.00V to prevent any safety events. And cell performance can't be guaranteed between 2.50V and 2.00V	Min 2.00V (Refer to 6.2)
2.12 Weight	With Tube and Washer	67.5 ± 1.0g
2.11.1 Operating Temperature ⁵⁾ (Atmosphere Temperature)	Charge	0 ~ 45°C
	Discharge	-30 ~ 55°C
2.11.2 Operating Temperature ⁵⁾ (Cell Surface Temperature)	Charge	0 ~ 55°C
	Discharge	-30 ~ 70°C
	* Max. cell surface temperature should be controlled by BMU protection unit below 55°C for charging and 70°C for discharging	
2.12 Storage Temperature ⁶⁾ (for shipping state ¹⁾ (Atmosphere Temperature)	1 month	-20 ~ 55°C
	3 month	-20 ~ 45°C
	1 year	-20 ~ 25°C
	Recovery capacity ⁷⁾ after the storage ≥ 80% of minimum energy(or capacity)	
2.13 Storage Temperature ⁶⁾ (for fully charged state) (Atmosphere Temperature)	1 month	-20 ~ 45°C
	6 month	-20 ~ 25°C
	Recovery capacity ⁷⁾ after the storage ≥ 80% of minimum energy(or capacity)	
2.14 Storage Humidity		Under 50%

Safety function description:

In order to achieve the required safety requirement, the Battery Management System is designed according to EN ISO 13849-1:2023 clause 6.1.3.2 designated architectures to achieve the required performance level $PL_r = C$.

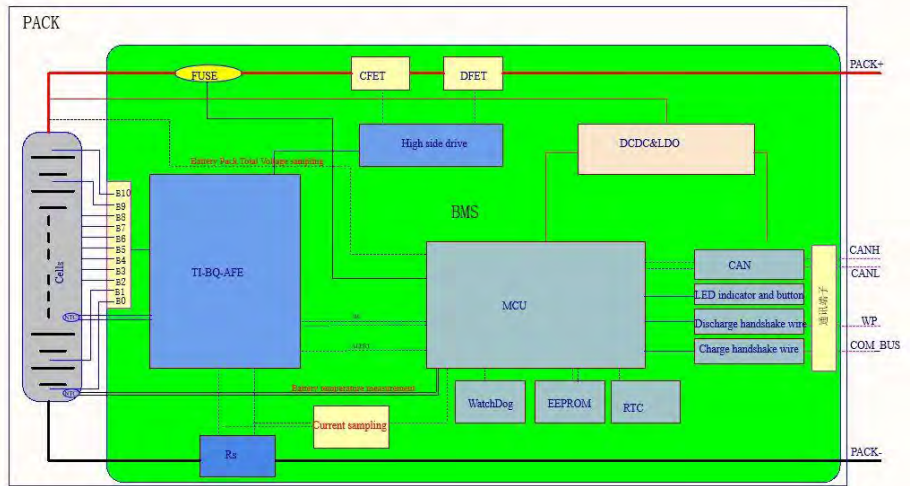

Figure 5 Topology diagram of design

SF-01. Safety function of Voltage control:

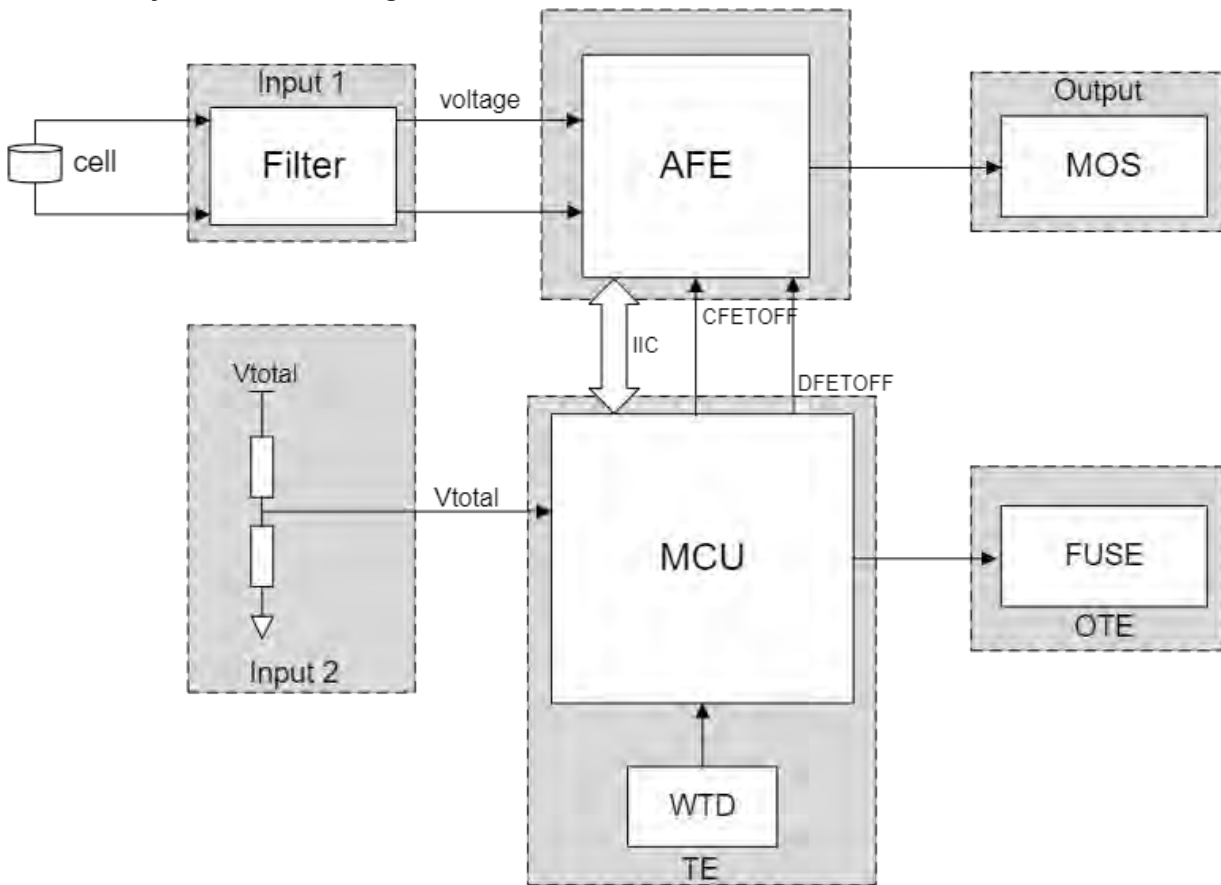

Figure 6 Simplified Equivalent Model of Voltage control function

- Brief description of designated architecture:

The Designated architecture of the Safety function of Voltage control is classified as Category 2

- AFE samples the cell voltages and compares the voltage with the threshold internally, when there is an over or under voltage, AFE switch off the charge or discharge MOS ;
- MCU samples the total voltage and compares the voltage with the threshold internally, when there is an over or under voltage, MCU set CFETOFF and DFETOFF signals low and AFE switch off the charge or discharge MOS;
- The IIC communication between MCU and AFE has CRC check;
- AFE's status is monitored by the CRC and the status flag in the IIC communication, when AFE fails, MCU switch off the fuse;
- MCU has an internal and an external watch dog to monitor its states. A reset generates to reset MCU when the program running away;
- MCU has startup and running test, when a failure is detected, MCU shut down the 3.3V power supply and reset, because the CFETOFF and DFETOFF signals are pull down, AFE switch off the MOS, system goes to fail safe state;
- When AFE switch off the MOS and there still have current flows, the MOS is short;
- When the MOS is short, MCU switch off the fuse;
- Warning information is send to the host through CAN bus.

- Brief description of diagnostic measures:

i Input: DC = 90%

cross monitoring of inputs with dynamic test: cross check the voltage by MCU and AFE

ii Logic: DC = 60%

variable memory: RAM-test by use of redundant data e.g. flags, markers, constants, timers and cross comparison of these data;

variable memory: check for readability and write ability of used data memory cells;

processing unit: self-test by software;

IIC communication CRC check;

AFE status flag in IIC;

iii output: DC = 90%

indirect monitoring: monitor the MOS by the MOS instruction from AFE and the loop current.

CCF analysis:

Scoring process and quantification of measures against CCF

No.	Measure against CCF	Score	Evidence
1	separation/segregation	<input type="checkbox"/> 15 <input type="checkbox"/> 0	
2	Diversity	<input checked="" type="checkbox"/> 20 <input type="checkbox"/> 0	Use AFE and MCU to monitor the voltage
3	design/application/experience		
- 3.1	protection against over-voltage, over-pressure, over-current, over-temperature	<input checked="" type="checkbox"/> 15 <input type="checkbox"/> 0	BMS system protect over voltage and temperature
- 3.2	components used are well-tried	<input checked="" type="checkbox"/> 5 <input type="checkbox"/> 0	

4	assessment/analysis	<input checked="" type="checkbox"/> 5	<input type="checkbox"/> 0	FMEA analysis
5	training	<input type="checkbox"/> 5	<input type="checkbox"/> 0	
6	environmental			
- 6.1	prevention of EMI or impurity of fluidic medium	<input checked="" type="checkbox"/> 25	<input type="checkbox"/> 0	EMC test
- 6.2	other influences	<input checked="" type="checkbox"/> 10	<input type="checkbox"/> 0	Consideration of the requirements for immunity to all relevant environmental influences such as, temperature, shock, vibration, humidity
	Total	80		
Total score		Measure for avoiding CCF		
65 or better		<input checked="" type="checkbox"/> Meets the requirements		
Less than 65		<input type="checkbox"/> Process failed ⇒ apply additional measures		

SF-02 Safety function of Current control:

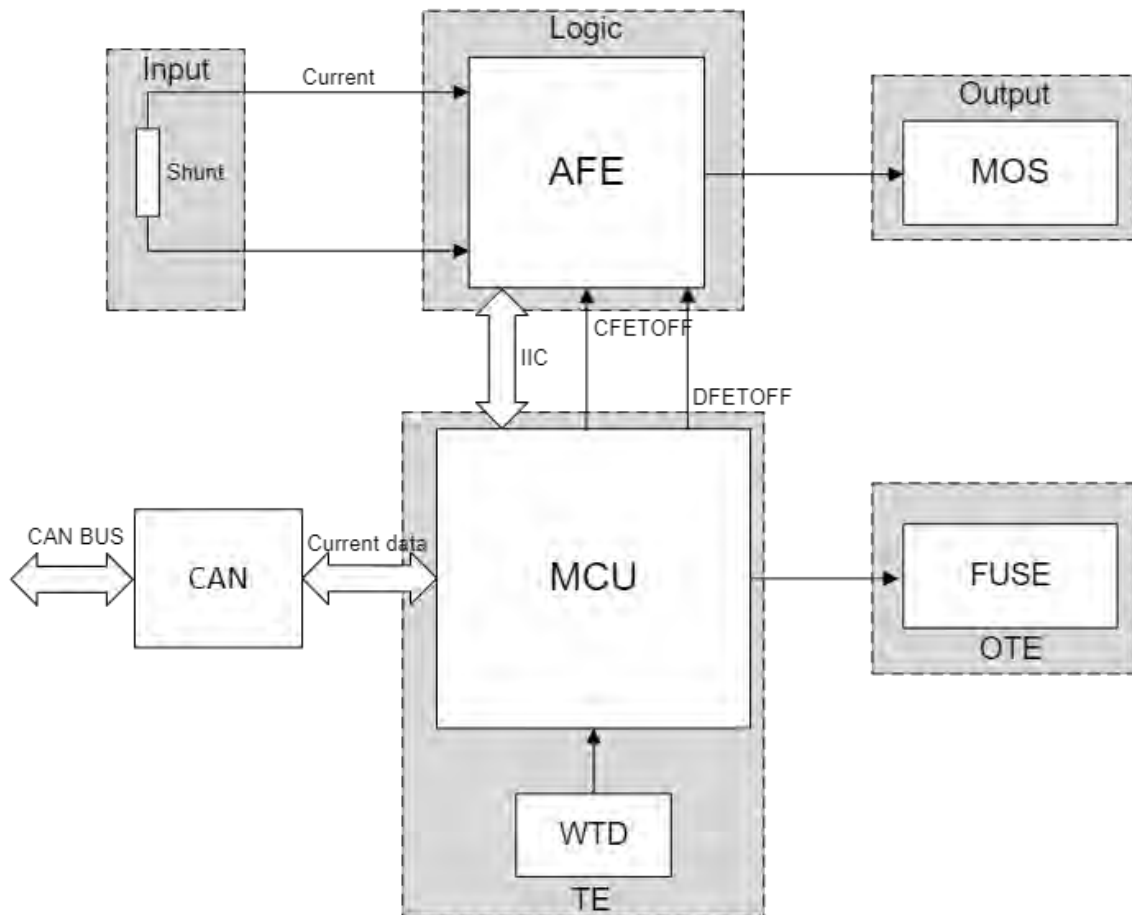

Figure 7 Simplified Equivalent Model of Current control function

- Brief description of designated architecture:

The Designated architecture of the Safety function of current control is classified as Category 2

- AFE samples the shunt voltage when current flows through the shunt, and then compares the voltage with the threshold internally, when an overcurrent happens, AFE switch off the charge or discharge MOS;
- AFE sends the shunt voltage to MCU via IIC communication;
- MCU receive the current from the external control unit, and compares the current with the current from AFE, when there is a deviation of $\pm 5\%$, MCU sets CFETOFF and DFETOFF signal to switch off MOS;
- The IIC communication between MCU and AFE has CRC check;
- AFE's status is monitored by the CRC and the status flag in the IIC communication, when AFE fails, MCU switch off the fuse;
- MCU has an internal and an external watch dog to monitor its states. A reset generates to reset MCU when the program running away;
- MCU has startup and running test, when a failure is detected, MCU shut down the 3.3V power supply and reset, because the CFETOFF and DFETOFF signals are pull down, AFE switch off the MOS, system goes to fail safe state;
- When AFE switch off the MOS and there still have current flows, the MOS is short;
- When the MOS is short, MCU switch off the fuse;
- Warning information is send to the host through CAN bus.

- Brief description of diagnostic measures:

i Input: DC = 90%

cross monitoring of inputs with dynamic test: cross check the current by MCU and AFE;

ii Logic: DC = 60%

variable memory: RAM-test by use of redundant data e.g. flags, markers, constants, timers and cross comparison of these data;

variable memory: check for readability and write ability of used data memory cells;

processing unit: self-test by software;

IIC communication CRC check;

AFE status flag in IIC;

iii output: DC = 90%

indirect monitoring: monitor the MOS by the MOS instruction from AFE and the loop current.

-CCF analysis:

Scoring process and quantification of measures against CCF

No.	Measure against CCF	Score	Evidence
1	separation/segregation	<input type="checkbox"/> 15 <input type="checkbox"/> 0	
2	Diversity	<input checked="" type="checkbox"/> 20 <input type="checkbox"/> 0	Use AFE and MCU to monitor the current
3	design/application/experience		

- 3.1	protection against over-voltage, over-pressure, over-current, over-temperature	<input checked="" type="checkbox"/> 15 <input type="checkbox"/> 0	BMS system protect over voltage and temperature
- 3.2	components used are well-tried	<input checked="" type="checkbox"/> 5 <input type="checkbox"/> 0	
4	assessment/analysis	<input checked="" type="checkbox"/> 5 <input type="checkbox"/> 0	FMEA analysis
5	training	<input type="checkbox"/> 5 <input type="checkbox"/> 0	
6	environmental		
- 6.1	prevention of EMI or impurity of fluidic medium	<input checked="" type="checkbox"/> 25 <input type="checkbox"/> 0	EMC test
- 6.2	other influences	<input checked="" type="checkbox"/> 10 <input type="checkbox"/> 0	Consideration of the requirements for immunity to all relevant environmental influences such as, temperature, shock, vibration, humidity
	Total	80	
Total score		Measure for avoiding CCF	
65 or better		<input checked="" type="checkbox"/> Meets the requirements	
Less than 65		<input type="checkbox"/> Process failed ⇒ apply additional measures	

SF-03 Safety function of Temperature control:

Figure 8 Simplified Equivalent Model of Temperature control function

- Brief description of designated architecture:

The Designated architecture of the Safety function of temperature control is classified as Category 2

- AFE samples NTC1's voltage which represents the cell temperature and compares it with the threshold internally, when there is a high or low temperature, AFE switch off the charge or discharge MOS;
- AFE sends the NTC1 temperature via IIC communication;
- MCU samples the NTC2 voltage which also represents the cell temperature, and compares with the temperature from NTC1 to judge if the NTC1 is short or open, when there is a temperature deviation of 10 degree , MCU sets CFETOFF and DFETOFF signal to switch off MOS;
- The IIC communication between MCU and AFE has CRC check;
- AFE's status is monitored by the CRC and the status flag in the IIC communication, when AFE fails, MCU switch off the fuse;

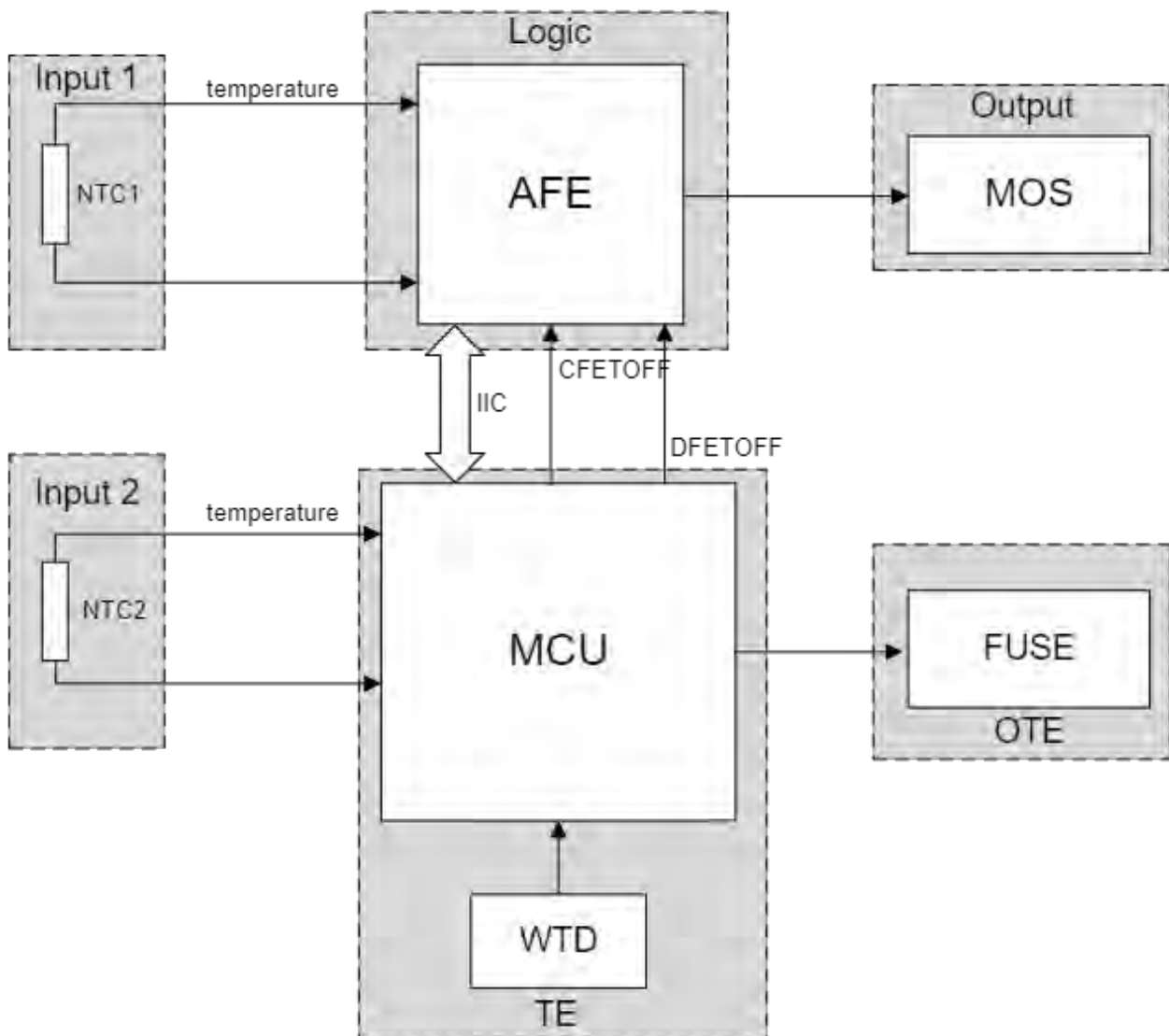
- MCU has an internal and an external watch dog to monitor its states. A reset generates to reset MCU when the program running away;
- MCU has startup and running test, when a failure is detected, MCU shut down the 3.3V power supply and reset, because the CFETOFF and DFETOFF signals are pull down, AFE switch off the MOS, system goes to fail safe state;
- When AFE switch off the MOS and there still have current flows, the MOS is short;
- When the MOS is short, MCU switch off the fuse;
- Warning information is send to the host through CAN bus.

- Brief description of diagnostic measures:

i Input: DC = 90%

cross monitoring of inputs with dynamic test: cross check the temperature by MCU and AFE;

ii Logic: DC = 60%

variable memory: RAM-test by use of redundant data e.g. flags, markers, constants, timers and cross comparison of these data;

variable memory: check for readability and write ability of used data memory cells;

processing unit: self-test by software;

IIC communication CRC check;

AFE status flag in IIC;

iii output: DC = 90%

indirect monitoring: monitor the MOS by the MOS instruction from AFE and the loop current.

- CCF analysis:

Scoring process and quantification of measures against CCF

No.	Measure against CCF	Score	Evidence
1	separation/segregation	<input type="checkbox"/> 15 <input type="checkbox"/> 0	
2	Diversity	<input checked="" type="checkbox"/> 20 <input type="checkbox"/> 0	Use AFE and MCU to monitor the temperature
3	design/application/experience		
- 3.1	protection against over-voltage, over-pressure, over-current, over-temperature	<input checked="" type="checkbox"/> 15 <input type="checkbox"/> 0	BMS system protect over voltage and temperature
- 3.2	components used are well-tried	<input checked="" type="checkbox"/> 5 <input type="checkbox"/> 0	
4	assessment/analysis	<input checked="" type="checkbox"/> 5 <input type="checkbox"/> 0	FMEA analysis
5	training	<input type="checkbox"/> 5 <input type="checkbox"/> 0	
6	environmental		
- 6.1	prevention of EMI or impurity of fluidic medium	<input checked="" type="checkbox"/> 25 <input type="checkbox"/> 0	EMC test
- 6.2	other influences	<input checked="" type="checkbox"/> 10 <input type="checkbox"/> 0	Consideration of the requirements for immunity to all relevant environmental influences such as,

			temperature, shock, vibration, humidity
	Total	80	
Total score	Measure for avoiding CCF		
65 or better	<input checked="" type="checkbox"/> Meets the requirements		
Less than 65	<input type="checkbox"/> Process failed ⇒ apply additional measures		

Safety-related software analysis

Embedded Software specification and design document for BMS are provided.

IDE: Keil Version: V5.29.0.0;

Language: C;

Code standard: MISRA C-2012;

Compiler: Keil;

Buring to Hardware: N32L406CBL7;

Static test: Tscancode, Version: 2.14.24.01;

The whole development procedure followed the V-mode base on support document. The function safety related modules are well isolated with other function blocks. Source code is written with well-defined programming specification and passed the static analysis. Black box test and integrated test have been done and meets the design requirement.

Measures to control the system failures have been taken into consideration.

External Watch dog provided to check the random hardware/software failures of MCU.

Core self-test library and ECC on flash and SRAM MCU have been applied to check the random hardware failure of MCU system.

CRC check is provided for the data correctness check within data communication.

When communication is broken, warning message will be sent to up level system and the charge/discharge will be cut off.

Verified version of the Safety-related embedded software and firmware identification code:

Item	Description
Hardware version	A01
Software version	V11
Checksum code	0x2144DF1C
The Checksum code generation tool	Hash_1.0.4

ISO 13489-1			
Clause	Requirement	Result - Remark	Verdict
1	Scope		—
	<p>This document specifies a methodology and provides related requirements, recommendations and guidance for the design and integration of safety-related parts of control systems (SRP/CS) that perform safety functions, including the design of software.</p> <p>This document applies to SRP/CS for high demand and continuous modes of operation including their subsystems, regardless of the type of technology and energy (e.g. electrical, hydraulic, pneumatic, and mechanical).</p> <p>This document does not apply to low demand mode of operation.</p>	Informative.	—
2	Normative references		—
3	Terms, definitions, symbols and abbreviated terms		—
4	Overview		P
5	Specification of safety functions		P
5.1	Identification and general description of the safety function		P
5.2	Safety requirements specification	The BMS evaluates the condition of cells and battery systems and maintains cells and battery systems within the specified cell operating region.	P
5.3	Determination of required performance level (PLr) for each safety function	PLr = C according to EN 50604-1: 2016+A1: 2021.	P
5.4	Review of the safety requirements specification (SRS)		P
5.5	Decomposition of SRP/CS into subsystems		P
6	Design considerations		P
6.1	Evaluation of the achieved performance level		P
6.1.1	General overview of performance level		P
6.1.2	Correlation between performance level (PL) and safety integrity level (SIL)	using PL _s according to this document.	P
6.1.3	Architecture — Categories and their relation to MTTFD of each channel, average diagnostic coverage and common cause failure (CCF)		P
6.1.3.1	General		P
6.1.3.2	Designated architectures — Specification of categories		P
6.1.3.2.1	General		P

ISO 13489-1			
Clause	Requirement	Result - Remark	Verdict
6.1.3.2.2	Category B		NA
6.1.3.2.3	Category 1		NA
6.1.3.2.4	Category 2	All safety function.	P
6.1.3.2.5	Category 3		NA
6.1.3.2.6	Category 4		NA
6.1.4	Mean time to dangerous failure (MTTF _D)	a) use manufacturer's data; b) use methods in Annex C;	P
6.1.5	Diagnostic coverage (DC)	Evaluation provided.	P
6.1.6	Common cause failures (CCFs)	Evaluation provided.	P
6.1.7	Systematic failures		P
6.1.8	Simplified procedure for estimating the performance level for subsystems	Applied.	P
6.1.9	Alternative procedure to determine the performance level and PFH without MTTF _D	6.1.8 applied.	NA
6.1.10	Fault consideration and fault exclusion		NA
6.1.11	<p>Well-tried component</p> <p>A well-tried component for safety-related applications is a component, which shall be either:</p> <p>a) widely used in the past with documented successful results in similar applications, or</p> <p>NOTE See IEC 61508-2:2010, 7.4.10, for "proven in use".</p> <p>b) listed in ISO 13849-2:2012, Annexes A to D, or</p> <p>c) made, verified and validated using principles which demonstrate its suitability and reliability for safety-related applications according to relevant product and application standards.</p> <p>The decision to accept a particular component as being well-tried depends on the application, e.g. owing to the environmental influences.</p> <p>Complex components (e.g. PLC, microprocessor, and application-specific integrated circuit) shall not be considered as equivalent to well-tried.</p>	Informative.	—
6.2	Combination of subsystems to achieve an overall performance level of the safety function		NA
6.3	Software based manual parameterization		NA
6.3.1	General		NA
6.3.2	Influences on safety-related parameters		NA
6.3.3	Requirements for software based manual parameterization		NA

ISO 13489-1			
Clause	Requirement	Result - Remark	Verdict
6.3.4	Verification of the parameterization tool		NA
6.3.5	Documentation of software based manual parameterization		NA
7	Software safety requirements		P
7.1	General		P
7.2	Limited variability language (LVL) and full variability language (FVL)		P
7.2.1	Limited variability language (LVL) and full variability language (FVL)	Use C language, FVL	P
7.2.2	Full variability language (FVL)		P
7.2.3	Decision for limited variability language (LVL) or full variability language (FVL)		P
7.3	Safety-related embedded software (SRESW)		P
7.3.1	Design of safety-related embedded software (SRESW)		P
7.3.2	Alternative procedures for non-accessible embedded software		P
7.4	Safety-related application software (SRASW)		NA
8	Verification of the achieved performance level		P
	For each individual safety function, the PL of the related SRP/CS shall match or be greater than the required performance level (PL _r) determined according to 5.3 and 6.1.1. If this is not the case, iteration in the process described in Figure 4 is necessary.		P
	The PL of the different subsystems which are part of a safety function shall be greater than or equal to the PL _r of this safety function (see 5.3 and 6.1.1).		P
9	Ergonomic aspects of design		NA
10	Validation		P
10.1	Validation principles		P
10.1.1	General		P
10.1.2	Validation plan		P
10.1.3	Generic fault lists		P
10.1.4	Specific fault lists		P
10.1.5	Information for validation		P
10.2	Validation of the safety requirements specification (SRS)		P

ISO 13489-1			
Clause	Requirement	Result - Remark	Verdict
10.3	Validation by analysis		P
10.3.1	General		P
10.3.2	Analysis techniques		P
10.4	Validation by testing		P
10.4.1	General		P
10.4.2	Measurement accuracy		P
10.4.3	Additional requirements for testing		P
10.4.4	Number of test samples		P
10.4.5	Testing methods		P
10.5	Validation of the safety functions		P
10.6	Validation of the safety integrity of the SRP/CS		P
10.6.1	Validation of subsystem(s)		NA
10.6.2	Validation of measures against systematic failures		P
10.6.3	Validation of safety-related software		P
10.6.4	Validation of combination of subsystems		NA
10.6.5	Overall validation of safety integrity		P
10.7	Validation of environmental requirements		P
10.8	Validation record		P
10.9	Validation maintenance requirements		NA
11	Maintainability of SRP/CS		P
12	Technical documentation		P
	When designing an SRP/CS according to this document at least the following information relevant to the safety-related part shall be documented for internal purposes:		P
	a) SRS (see 5.2.1);		P
	b) exact points at which the safety-related part(s) starts and ends;		P
	c) decomposition into subsystems (see 5.2.2), if applicable;		NA
	d) environmental conditions (e.g. EMI immunity, temperature, vibration);		P
	e) achieved performance level and PFH value;		P
	f) category or categories selected (may not be applicable for previously validated subsystems);		P

ISO 13489-1			
Clause	Requirement	Result - Remark	Verdict
	g) parameters relevant to the reliability (MTTFD, DC, CCF and T10D) and the mission time;		P
	h) measures against systematic failure;		P
	i) the technology or technologies used;		NA
	j) the safety-relevant faults considered;		P
	k) justification for fault exclusions (see 6.1.10.3 and all annexes of ISO 13849-2:2012);		N/A
	l) software documentation if applicable;	See table 3	P
	m) measures against reasonably foreseeable misuse;		NA
	n) safety-related block diagram;		P
	o) relevant design documentation, test, verification and validation records, where applicable.	See table 3	P
13	Information for use		P
13.1	General		P
13.2	Information for SRP/CS integration	Provided.	P
13.3	Information for user	Provided.	P
Annex A	Guidance for the determination of required performance level (PLr)	Informative.	—
Annex B	Block method and safety-related block diagram	Informative.	—
Annex C	Calculating or evaluating MTTFD values for single components	Informative.	—
Annex D	Simplified method for estimating MTTFD for each channel	Informative.	—
Annex E	Estimates for diagnostic coverage (DC) for functions and subsystems	Informative.	—
Annex F	Method for quantification of measures against common cause failures (CCF)	Informative.	—
Annex G	Systematic failure	Informative.	—
Annex H	Example of a combination of several subsystems	Informative.	—
Annex I	Examples for the simplified procedure to estimate the PL of subsystems	Informative.	—
Annex J	Example of SRESW realisation	Informative.	—
Annex L	Electromagnetic interference (EMI) immunity	Informative.	—
Annex N	Avoiding systematic failure in software design	Informative.	—

ISO 13489-1			
Clause	Requirement	Result - Remark	Verdict
Annex O	Safety-related values of components or parts of control systems	Informative.	—

ISO 13489-1			
Clause	Requirement	Result - Remark	Verdict

Table 2-1	Performance Level (PL) Calculation	P
	Safety function SF-01 Overvoltage / Under voltage protection	

PL_r	PL _r is ≥ C (according to EN 50604-1: 2016+A1: 2021)	
Designated architectures:	Category 2	
Components	MTTF_D specified by manufacturer	
Input	R(resistor)	114155
Input	C(capacitor)	22831
Logic	AFE	1426.9
Output	MOS	1903
TE	MCU	891.28
OTE	FUSE	1141.6

Estimates for MTTF_D and Diagnostic Coverage (DC) for functions and subsystems

Subsystem	MTTF _{D, subsystem}	DC _{avg}
- Input	2208	90%
- Logic	1151.9	60%
- Output	819	90%
- TE	891.28	--
- OTE		--

6.1.8 Simplified procedure for estimating the performance level for subsystems

Result	Performance Level (PL)	MTTF _{D, L}	DC _{avg}	Estimation of effect of measures against CCF
		100	79.8%	80
	C	High	Low	Meets the requirements

Supplementary information:

For Category 2 according to ISO 13849-2:2012,

- 1) The check(s) provided by the checking equipment do not introduce an unsafe state;
- 2) The checking equipment detects all relevant faults applied, one at a time, during the checking process and generates an appropriate control action which initiates a safe state.
- 3) The initiation of the check is carried out
 - 3.1) at the machine start-up and prior to the initiation of a hazardous situation, and
 - 3.2) periodically, during operation in accordance with the design specification and if the risk assessment and kind of operations show that it is necessary;
- 4) The MTTF_d of the functional channel (MTTF_{d, L}) is at least 3 years;
- 5) The MTTF_{d, TE} (891.28) is larger than half of MTTF_{d, L} (576);
- 6) the test rate ≥ 100 × expected demand rate.

ISO 13489-1			
Clause	Requirement	Result - Remark	Verdict

Table 2-2	Performance Level (PL) Calculation Safety function SF-02 Over current protection	P
------------------	---	----------

PL_r	PL _r is ≥ C (according to EN 50604-1: 2016+A1: 2021)	
Designated architectures:	Category 2	
Components	MTTF_D specified by manufacturer	
Input	shunt	228310
Logic	AFE	1426.9
Output	MOS	1903
TE	MCU	891.28
OTE	FUSE	1141.6

Estimates for MTTF_D and Diagnostic Coverage (DC) for functions and subsystems

Subsystem	MTTF _{D, subsystem}	DC _{avg}
- Input	30441	90%
- Logic	1157.7	60%
- Output	819	90%
- TE	891.28	--
- OTE		--

6.1.8 Simplified procedure for estimating the performance level for subsystems

Result	Performance Level (PL)	MTTF _{D, L}	DC _{avg}	Estimation of effect of measures against CCF
		100	77.76%	80
	C	High	Low	Meets the requirements

Supplementary information:

For Category 2 according to ISO 13849-2:2012,

- 1) The check(s) provided by the checking equipment do not introduce an unsafe state;
- 2) The checking equipment detects all relevant faults applied, one at a time, during the checking process and generates an appropriate control action which initiates a safe state.
- 3) The initiation of the check is carried out
 - 3.1) at the machine start-up and prior to the initiation of a hazardous situation, and
 - 3.2) periodically, during operation in accordance with the design specification and if the risk assessment and kind of operations show that it is necessary;
- 4) The MTTF_d of the functional channel (MTTF_{d, L}) is at least 3 years;
- 5) The MTTF_{d, TE} (891.2) is larger than half of MTTF_{d, L} (578.8);
- 6) the test rate ≥ 100 × expected demand rate.

ISO 13489-1			
Clause	Requirement	Result - Remark	Verdict

Table 2-3	Performance Level (PL) Calculation	P
	Safety function SF-03 Over temperature / Under temperature protection	

PL_r	PL _r is ≥ C (according to EN 50604-1: 2016+A1: 2021)	
Designated architectures:	Category 2	
Components	MTTF_D specified by manufacturer	
Input	NTC	3805
Logic	AFE	1426.9
Output	DMOS	1903
Output	CMOS	1903
TE	MCU	891.28
OTE	FUSE	1141.6

Estimates for MTTF_D and Diagnostic Coverage (DC) for functions and subsystems

Subsystem	MTTF _{D, subsystem}	DC _{avg}
- Input	3512	90%
- Logic	1157.7	60%
- Output	819	90%
- TE		--
- OTE		--

6.1.8 Simplified procedure for estimating the performance level for subsystems

Result	Performance Level (PL)	MTTF _{D, L}	DC _{avg}	Estimation of effect of measures against CCF
		100	79.06%	80
	C	High	Low	Meets the requirements

Supplementary information:

For Category 2 according to ISO 13849-2:2012,

- 1) The check(s) provided by the checking equipment do not introduce an unsafe state;
- 2) The checking equipment detects all relevant faults applied, one at a time, during the checking process and generates an appropriate control action which initiates a safe state.
- 3) The initiation of the check is carried out
 - 3.1) at the machine start-up and prior to the initiation of a hazardous situation, and
 - 3.2) periodically, during operation in accordance with the design specification and if the risk assessment and kind of operations show that it is necessary;
- 4) The MTTF_d of the functional channel (MTTF_{d, L}) is at least 3 years;
- 5) The MTTF_{d, TE} (891.28) is larger than half of MTTF_{d, L} (578.8);
- 6) the test rate ≥ 100 × expected demand rate.

Table 3: Manufacturer's Documentation Referenced in this TRF (informative)		
Title	Version	Date
ISO9001: 2015 Quality Management	--	2022.04.28
Hardware Circuit_V01	V00	2023.10.20
BOM_LDL3	--	--
LIDL 3.0 BMS Safety Plan	V01	2024.07.19
LIDL 3.0-BMS FMEDA_MTTFd_calaulation	V01	2024.08.19
LIDL 3.0 Rechargeable lithium battery pack EMC test report	01	2024.09.19
LIDL 3.0-BMS System Architecture Specification	V01	2024.09.23
LIDL 3.0-BMS Software Safety Requirement Specification	V01	2024.09.25
LIDL 3.0 BMS Software Architecture Specification	V01	2024.09.27
LIDL 3.0 BMS Software Design Specification	V01	2024.09.27
LIDL 3.0-BMS Software static test Report	V01	2024.09.30
LIDL 3.0-BMS Software validation Specification	V01	2024.09.30
ME(PLAB)-SP-02A Software development 20240716 NQ	A	2024.07.08
TB(ME)-RD-F001L Change Management	L	2024.07.19

-- End --

Product: Rechargeable Li-ion Battery system

Type: E36100E-ST3 E36100B-ST1 E36200L-IT3A1 E36150A-AL3



Figure 1 Front view of product (E36100E-ST3)

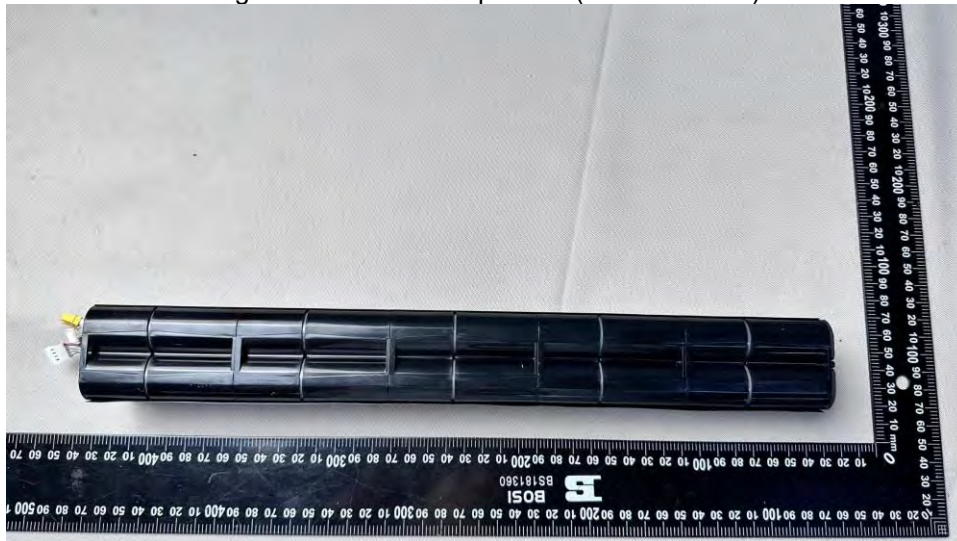

Figure 2 Back view of product (E36100E-ST3)

Product: Rechargeable Li-ion Battery system

Type: E36100E-ST3 E36100B-ST1 E36200L-IT3A1 E36150A-AL3

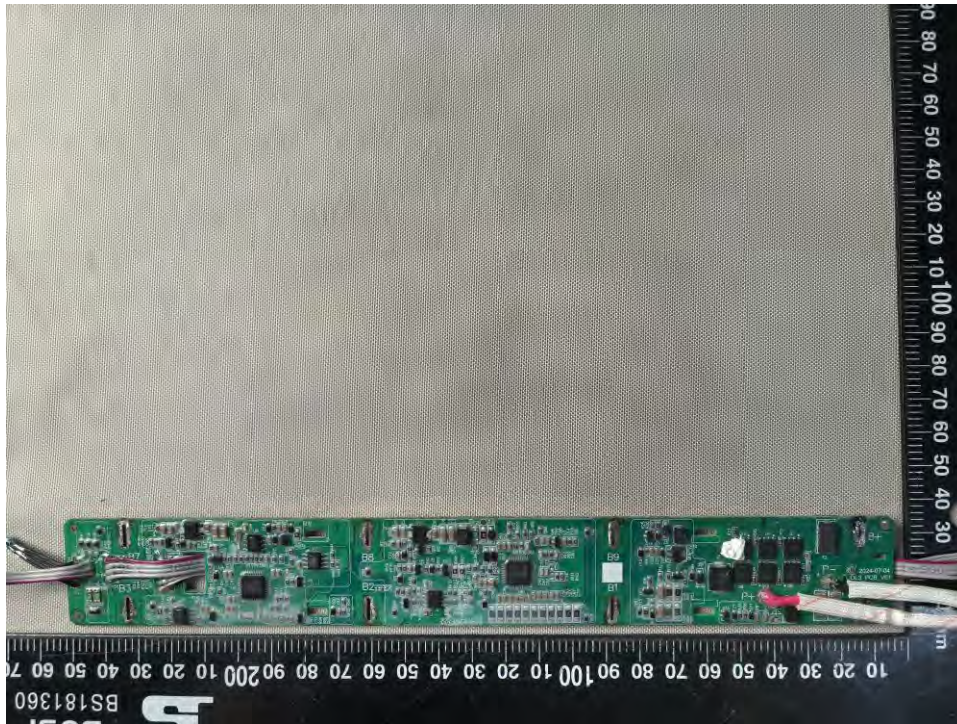

Figure 3 Top view of PCBA(E36100E-ST3)



Figure 4 Bottom view of PCBA(E36100E-ST3)

Product: Rechargeable Li-ion Battery system

Type: E36100E-ST3 E36100B-ST1 E36200L-IT3A1 E36150A-AL3



Figure 5 Top view of product(E36200L-IT3A1)

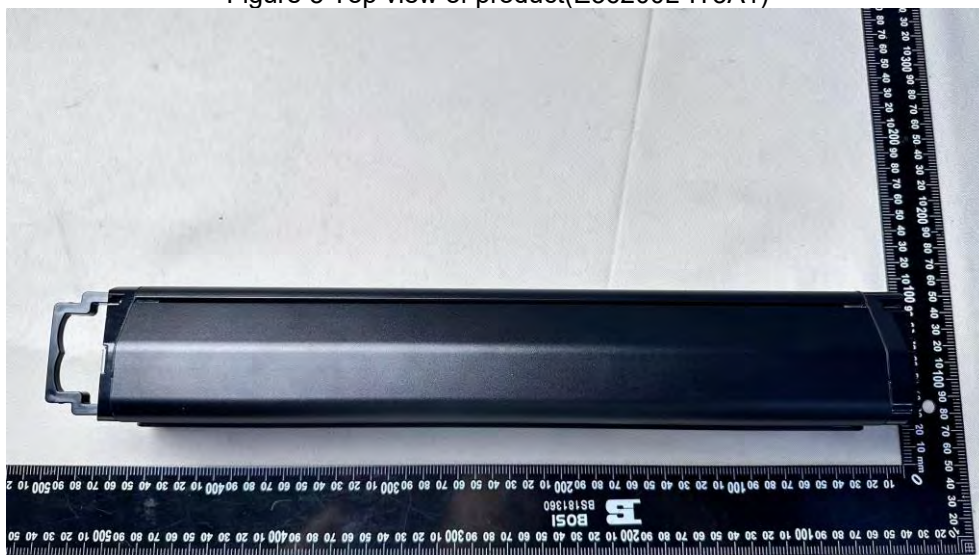

Figure 6 Back view of product(E36200L-IT3A1)

Product: Rechargeable Li-ion Battery system

Type: E36100E-ST3 E36100B-ST1 E36200L-IT3A1 E36150A-AL3

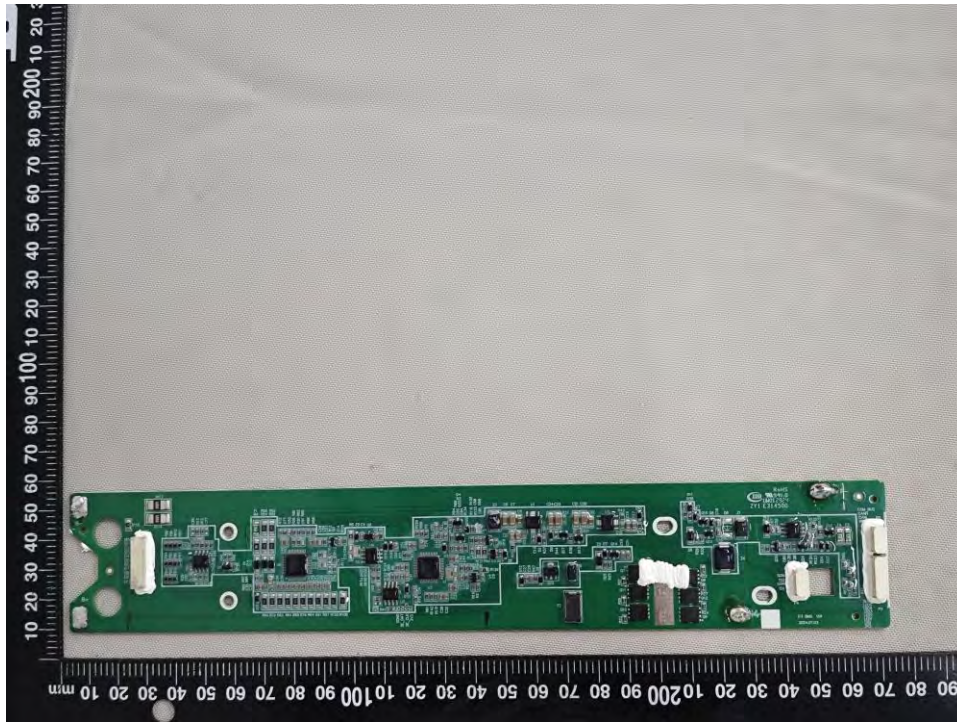

Figure 7 Top view of PCBA(E36200L-IT3A1)

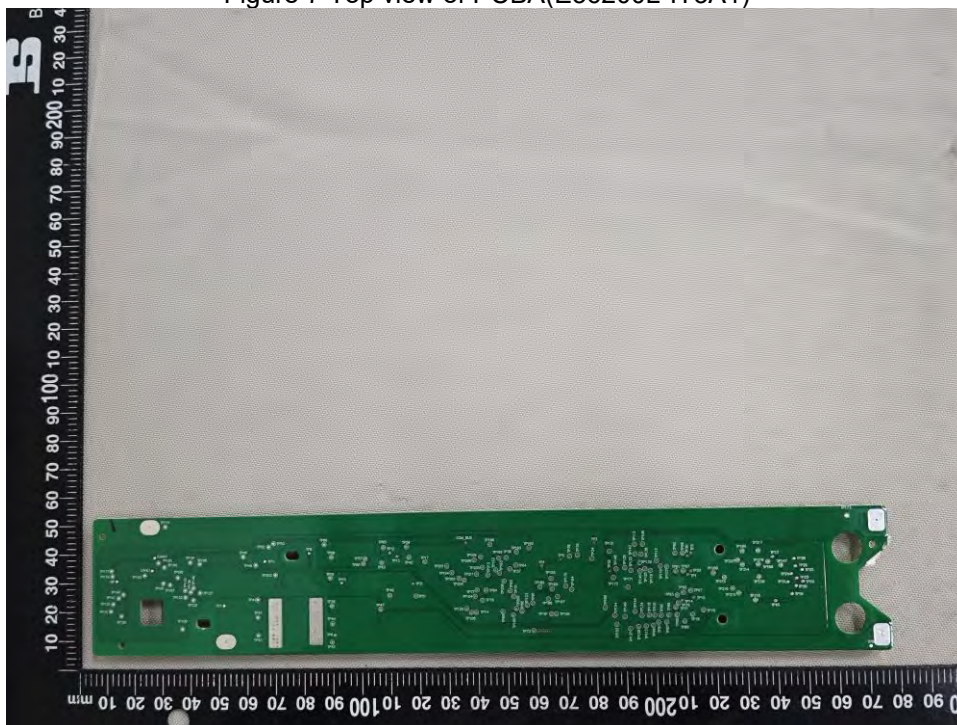

Figure 8 Bottom view of PCBA(E36200L-IT3A1)

Product: Rechargeable Li-ion Battery system

Type: E36100E-ST3 E36100B-ST1 E36200L-IT3A1 E36150A-AL3



Figure 9 Top view of product(E36150A-AL3)



Figure 10 Back view of product(E36150A-AL3)

Product: Rechargeable Li-ion Battery system

Type: E36100E-ST3 E36100B-ST1 E36200L-IT3A1 E36150A-AL3

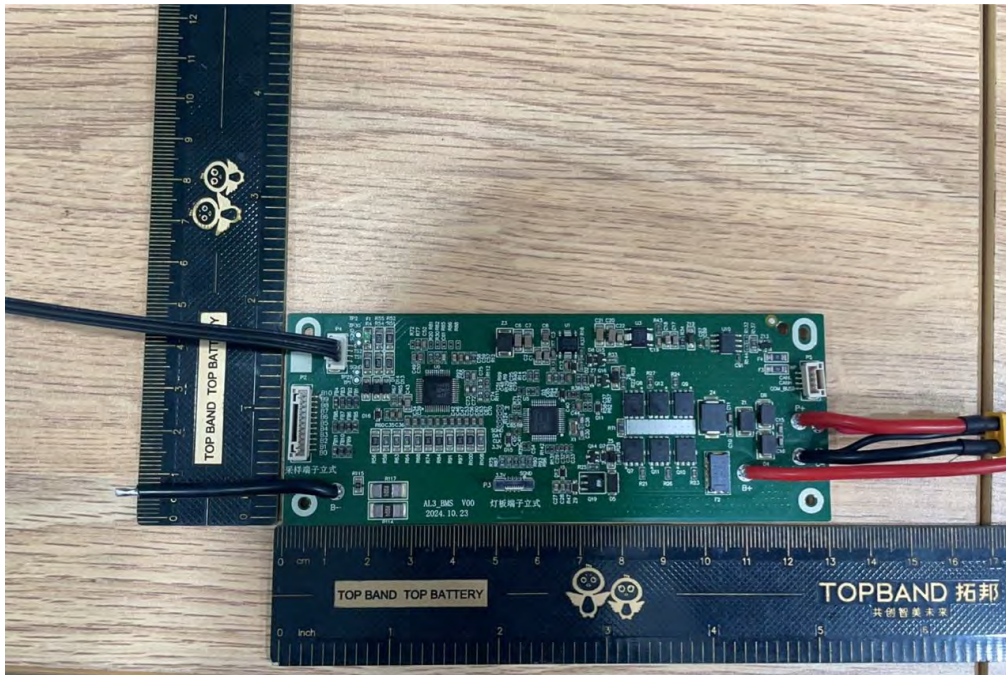

Figure 11 Top view of PCBA(E36150A-AL3)



Figure 12 Bottom view of PCBA(E36150A-AL3)

Product: Rechargeable Li-ion Battery system

Type: E36100E-ST3 E36100B-ST1 E36200L-IT3A1 E36150A-AL3



Figure 13 Side view of Product(E36100B-ST1)



Figure 14 Top view of Product(E36100B-ST1)

Product: Rechargeable Li-ion Battery system

Type: E36100E-ST3 E36100B-ST1 E36200L-IT3A1 E36150A-AL3



Figure 15 Back view of Product(E36100B-ST1)



Figure 16 Top view of PCBA1(E36100B-ST1)

Product: Rechargeable Li-ion Battery system

Type: E36100E-ST3 E36100B-ST1 E36200L-IT3A1 E36150A-AL3

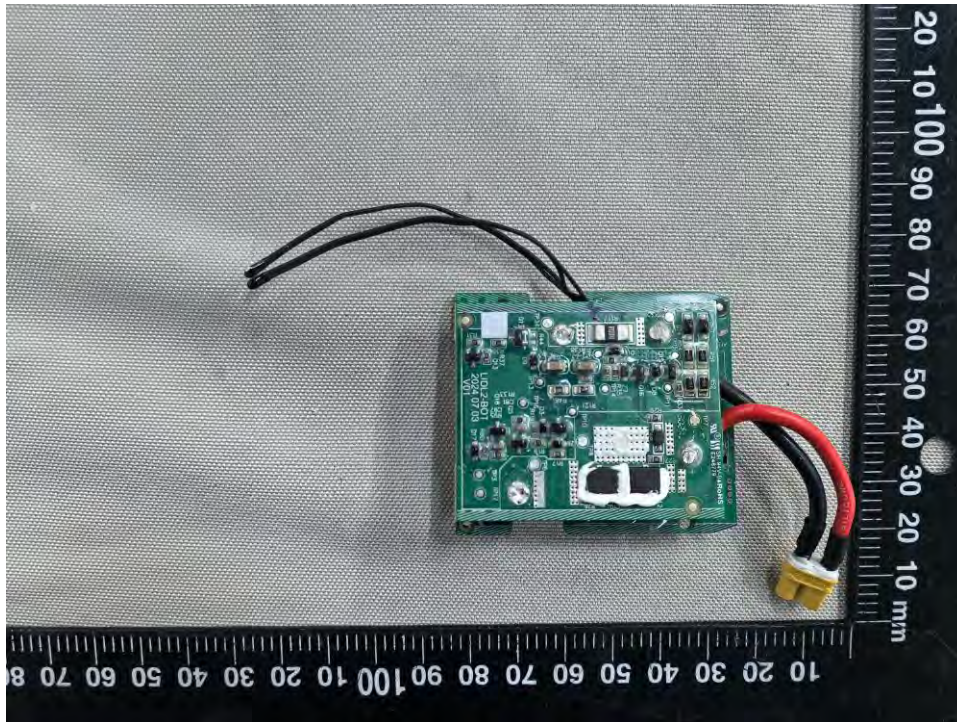

Figure 17 Bottom view of PCBA1(E36100B-ST1)

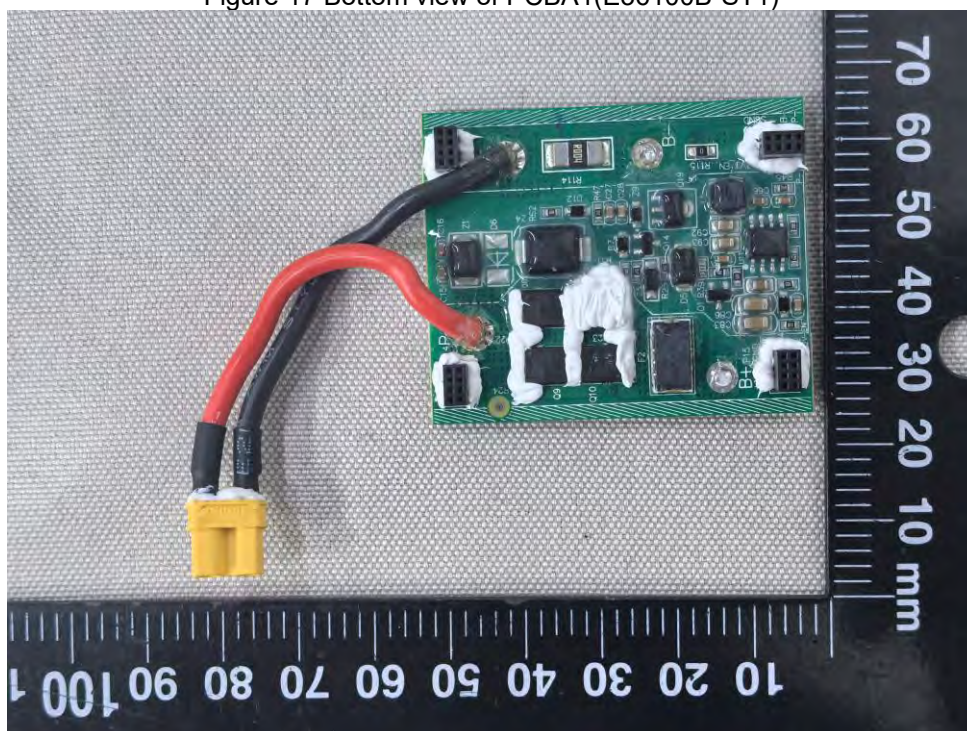

Figure 18 Top view of PCBA2(E36100B-ST1)

Product: Rechargeable Li-ion Battery system

Type: E36100E-ST3 E36100B-ST1 E36200L-IT3A1 E36150A-AL3

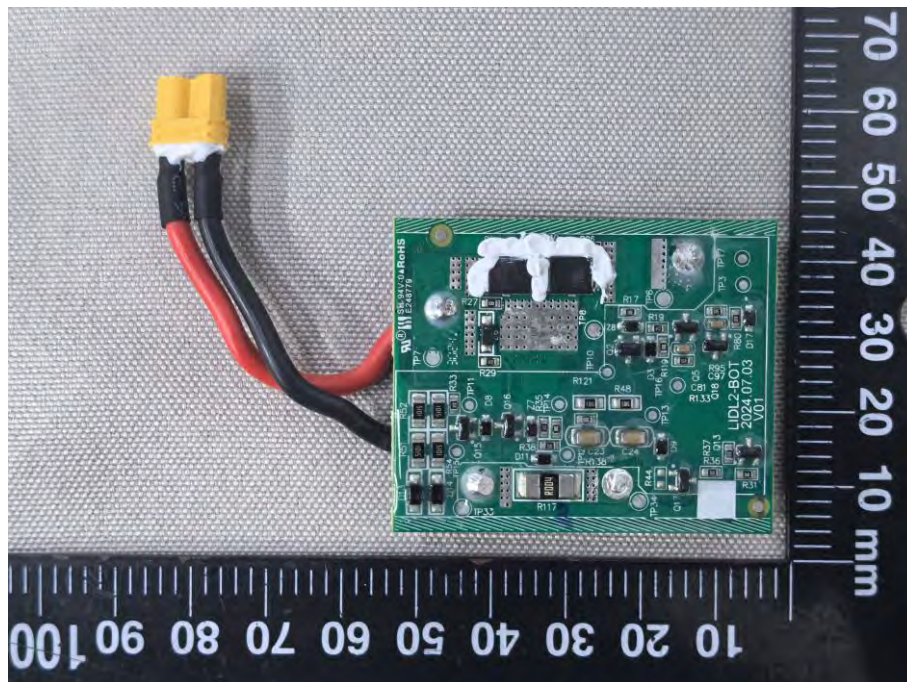





Figure 19 Bottom view of PCBA2(E36100B-ST1)

Prüfbericht-Nr.: <i>Test report no.:</i>	CN24BW6P 001	Auftrags-Nr.: <i>Order no.:</i>	168497397	Seite 1 von 25 Page 1 of 25
Kunden-Referenz-Nr.: <i>Client reference no.:</i>	N/A	Auftragsdatum: <i>Order date:</i>	2024-07-04	
Auftraggeber: <i>Client:</i>	Shenzhen Topband Co., Ltd 1F, the Second Phase of Topband Industrial Park, No.2 Sci-Tech Road, Tangtou Community, Shiyuan Street, Baoan District, Shenzhen, P.R. China			
Prüfgegenstand: <i>Test item:</i>	Li-ion Battery pack			
Bezeichnung / Typ-Nr.: <i>Identification / Type no.:</i>	E36100B-ST1			
Auftrags-Inhalt: <i>Order content:</i>	Test report			
Prüfgrundlage: <i>Test specification:</i>	EN 50604-1: 2016+A1: 2021			
Wareneingangsdatum: <i>Date of sample receipt:</i>	2024-08-05			
Prüfmuster-Nr.: <i>Test sample no.:</i>	A003824149-001- to 016			
Prüfzeitraum: <i>Testing period:</i>	2024-09-25 - 2024-11-14			
Ort der Prüfung: <i>Place of testing:</i>	TÜV Rheinland (Shenzhen) Co., Ltd.			
Prüflaboratorium: <i>Testing laboratory:</i>	TÜV Rheinland (Shenzhen) Co., Ltd.			
Prüfergebnis*: <i>Test result*:</i>	Pass			
erstellt von: <i>created by:</i>	 Kaman Qiu	genehmigt von: <i>authorized by:</i>	 Revan Dai	
Datum: <i>Date:</i>	2024-12-12	Ausstellungsdatum: <i>Issue date:</i>	2024-12-12	
Stellung / Position:	Project Engineer	Stellung / Position:	Authorizer	
Sonstiges / <i>Other:</i>	This report does not evidence compliance of the provided sample with the relevant standards but only with the referred tests. This test report documents the findings of examination conducted on the delivered product mentioned above only. This report does not entitle the applicant to carry any safety mark on this or similar products. Further for sales or other application purposes of the tested product, any reference to TÜV Rheinland or a test through TÜV Rheinland is only permissible with prior written consent of TÜV Rheinland.			
Zustand des Prüfgegenstandes bei Anlieferung: <i>Condition of the test item at delivery:</i>	Prüfmuster vollständig und unbeschädigt <i>Test item complete and undamaged</i>			
* Legende:	P(ass) = entspricht o.g. Prüfgrundlage(n)	F(ail) = entspricht nicht o.g. Prüfgrundlage(n)	N/A = nicht anwendbar	N/T = nicht getestet
* Legend:	P(ass) = passed a.m. test specification(s)	F(ail) = failed a.m. test specification(s)	N/A = not applicable	N/T = not tested
Dieser Prüfbericht bezieht sich nur auf das o.g. Prüfmuster und darf ohne Genehmigung der Prüfstelle nicht auszugsweise vervielfältigt werden. Dieser Bericht berechtigt nicht zur Verwendung eines Prüfzeichens. <i>This test report only relates to the above mentioned test sample. Without permission of the test center this test report is not permitted to be duplicated in extracts. This test report does not entitle to carry any test mark.</i>				

Prüfbericht-Nr.: CN24BW6P 001
Test report no.:

Seite 2 von 25
Page 2 of 25

Anmerkungen
Remarks

- | | |
|---|--|
| 1 | <p>Alle eingesetzten Prüfmittel waren zum angegebenen Prüfzeitraum gemäß eines festgelegten Kalibrierungsprogramms unseres Prüfhauses kalibriert. Sie entsprechen den in den Prüfprogrammen hinterlegten Anforderungen. Die Rückverfolgbarkeit der eingesetzten Prüfmittel ist durch die Einhaltung der Regelungen unseres Managementsystems gegeben.
Detaillierte Informationen bezüglich Prüfkonditionen, Prüfequipment und Messunsicherheiten sind im Prüflabor vorhanden und können auf Wunsch bereitgestellt werden.</p> <p><i>The equipment used during the specified testing period was calibrated according to our test laboratory calibration program. The equipment fulfils the requirements included in the relevant standards. The traceability of the test equipment used is ensured by compliance with the regulations of our management system. Detailed information regarding test conditions, equipment and measurement uncertainty is available in the test laboratory and could be provided on request.</i></p> |
| 2 | <p>Wie vertraglich vereinbart, wurde dieses Dokument nur digital unterzeichnet. Der TÜV Rheinland hat nicht überprüft, welche rechtlichen oder sonstigen diesbezüglichen Anforderungen für dieses Dokument gelten. Diese Überprüfung liegt in der Verantwortung des Benutzers dieses Dokuments. Auf Verlangen des Kunden kann der TÜV Rheinland die Gültigkeit der digitalen Signatur durch ein gesondertes Dokument bestätigen. Diese Anfrage ist an unseren Vertrieb zu richten. Eine Umweltgebühr für einen solchen zusätzlichen Service wird erhoben. Informationen zur Verifizierung der Authentizität unserer Dokumente erhalten Sie auf folgender Webseite: go.tuv.com/digital-signature</p> <p><i>As contractually agreed, this document has been signed digitally only. TUV Rheinland has not verified and unable to verify which legal or other pertaining requirements are applicable for this document. Such verification is within the responsibility of the user of this document. Upon request by its client, TUV Rheinland can confirm the validity of the digital signature by a separate document. Such request shall be addressed to our Sales department. An environmental fee for such additional service will be charged. For information on verifying the authenticity of our documents, please visit the following website: go.tuv.com/digital-signature</i></p> |
| 3 | <p>Prüfklausel mit der Note * wurden an qualifizierte Unterauftragnehmer vergeben und sind unter der jeweiligen Prüfklausel des Berichts beschrieben.
Abweichungen von Prüfspezifikation(en) oder Kundenanforderungen sind in der jeweiligen Prüfklausel im Bericht aufgeführt.</p> <p><i>Test clauses with remark of * are subcontracted to qualified subcontractors and described under the respective test clause in the report.
Deviations of testing specification(s) or customer requirements are listed in specific test clause in the report.</i></p> |
| 4 | <p>Die Entscheidungsregel für Konformitätserklärungen basierend auf numerischen Messergebnissen in diesem Prüfbericht basiert auf der "Null-Grenzwert-Regel" und der "Einfachen Akzeptanz" gemäß ILAC G8:2019 und IEC Guide 115:2021, es sei denn, in der auf Seite 1 dieses Berichts genannten angewandten Norm ist etwas anderes festgelegt oder vom Kunden gewünscht. Dies bedeutet, dass die Messunsicherheit nicht berücksichtigt wird und daher auch nicht im Prüfbericht angegeben wird. Zu weiteren Informationen bezüglich des Risikos durch diese Entscheidungsregel siehe ILAC G8:2019.</p> <p><i>The decision rule for statements of conformity, based on numerical measurement results, in this test report is based on the "Zero Guard Band Rule" and "Simple Acceptance" in accordance with ILAC G8:2019 and IEC Guide 115:2021, unless otherwise specified in the applied standard mentioned on Page 1 of this report or requested by the customer. This means that measurement uncertainty is not taken in account and hence also not declared in the test report. For additional information to the resulting risk based of this decision rule please refer to ILAC G8:2019.</i></p> |

TEST REPORT EN 50604-1:2016+A1: 2021 Secondary lithium batteries for light EV (electric vehicle) applications - Part 1: General safety requirements and test methods	
Report Reference No.	CN24BW6P 001
Date of issue	See cover page
Total number of pages	See cover page
Applicant's name	See cover page
Address	See cover page
Test specification:	
Standard	EN 50604-1: 2016+A1: 2021
Test procedure	Test report
Non-standard test method	N/A
Test Report Form No.	EN 50604-1_2A
Test Report Form(s) Originator	TÜV Rheinland (Shenzhen) Co., Ltd.
Master TRF	Dated 2021-08
Test item description	Li-ion Battery pack
Trade Mark	N/A
Manufacturer	TOPBAND SMART DONG NAI (VIET NAM) COMPANY LIMITED Lot D, Loc An-Binh Son Industrial Park, Long An Commune, Long Thanh District, Dong Nai Province, Viet Nam
Model/Type reference	E36100B-ST1
Ratings	36.9VDC, 9.6Ah, 354.24Wh

List of Attachments (including a total number of pages in each attachment):

Attachment 1: Equipment list (1 page);

Attachment 2: Photo documentation (6 pages).

Tests performed (name of test and test clause):

6.101 Vibration
 6.102 Mechanical shock.
 6.103 Drop test
 7.1 Dewing (temperature change)
 7.2 Thermal-shock cycling
 8.101 Crush
 8.3 Water immersion
 8.102 Over-temperature condition
 8.103 Under-temperature condition
 9.1 Short-circuit
 9.101 Leakage current of a battery system while switched-off
 10.1 Overcharge protection
 10.2 Over-discharge protection
 10.3 Loss of thermal control
 10.4 Deep discharge protection
 BB.5 Label test

Testing location:

TÜV Rheinland (Shenzhen) Co., Ltd.
 1-5F, Block 5, No. 1100, Huanli Road, Yungu Community, Xinhua Street, Guangming District, Shenzhen, China

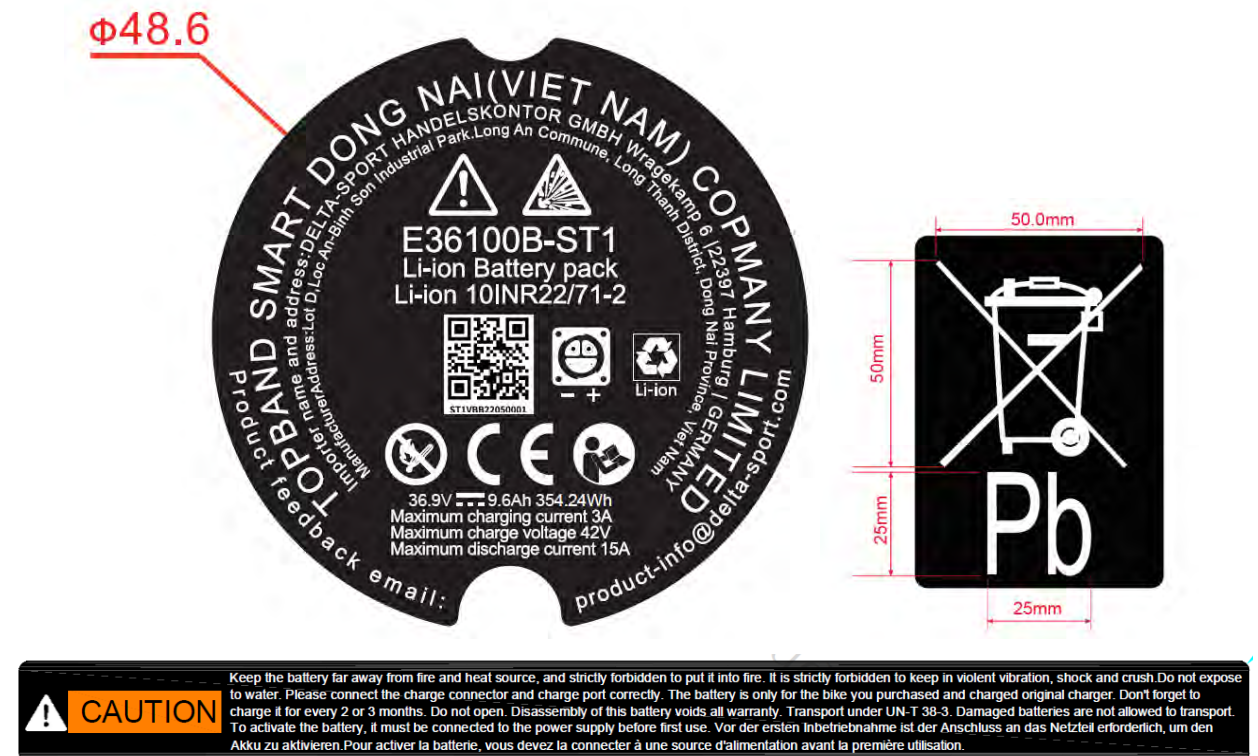
Copy of markings:

Remark:

Batch Number: "ST1VBB22050001",

"2205" represents the date of manufacture, "22" represents the year, "05" represents the month.

Test item particulars:	
Classification of installation and use	Battery for Light Electric Vehicle
Supply Connection	Terminal for the prepared conductor specified by the manufacturer
Protection against ingress of foreign objects and water	
	IPX7
Mass of equipment (kg)	2.4±0.1kg
Manufacturer recommended charge voltage (V) ...	42
Possible test case verdicts:	
Test case does not apply to the test object	N/A
Test object does meet the requirement	P (Pass)
Test object does not meet the requirement	F (Fail)
Testing:	
Date of receipt of test item	See cover page
Date(s) of performance of tests	See cover page
General remarks:	
<p>The test results presented in this report relate only to the object tested. This report shall not be reproduced, except in full, without the written approval of the Issuing testing laboratory.</p> <ul style="list-style-type: none"> • "(see Enclosure #)" refers to additional information appended to the report. • "(see appended table)" refers to a table appended to the report. • Throughout this report a point is used as the decimal separator. 	
Name and address of factory (ies)	Same as manufacturer

General product information:

The Rechargeable Li-ion Battery pack E36100B-ST1 is specially used as energy system for light electric vehicle (Removable EESS). It consists of 20 pcs cells (10S2P) and is integrated with the active protective device and passive protective device, which is intended to protect battery against abnormal operations.

The battery pack system mainly consists of:

- 20 pcs cells (CB approved by IEC 62133-2)
- BMS (Battery Management System)
- Plastic enclosure
- DC connectors as charge and discharger interfaces
- External charger

Specified charge temperature range: 0 to 40°C

Specified operating temperature range: -20°C to 50°C

The general parameters of the battery pack featured as follows:

Model	Rated capacity	Nominal voltage	Nominal Charge Current	Nominal Discharge Current	Maximum Charge Current	Maximum Discharge Current	Maximum Charge Voltage	End Discharge Voltage
E36100B-ST1	9.6Ah	36.9V	2.0A	7A	3.0A*	15.0A**	42.0V	28.0V

Remark:

* Maximum charging current of battery declared by manufacturer is 2880mA at 0°C to 10°C,
Maximum charging current of battery declared by manufacturer is 3000mA at 10°C to 40°C .

** Maximum discharging current of battery declared by manufacturer is 4800mA at -20°C to 10°C,
Maximum discharging current of battery declared by manufacturer is 15000mA at 10°C to 25°C,
Maximum discharging current of battery declared by manufacturer is 10000mA at 25°C to 50°C .

Construction:

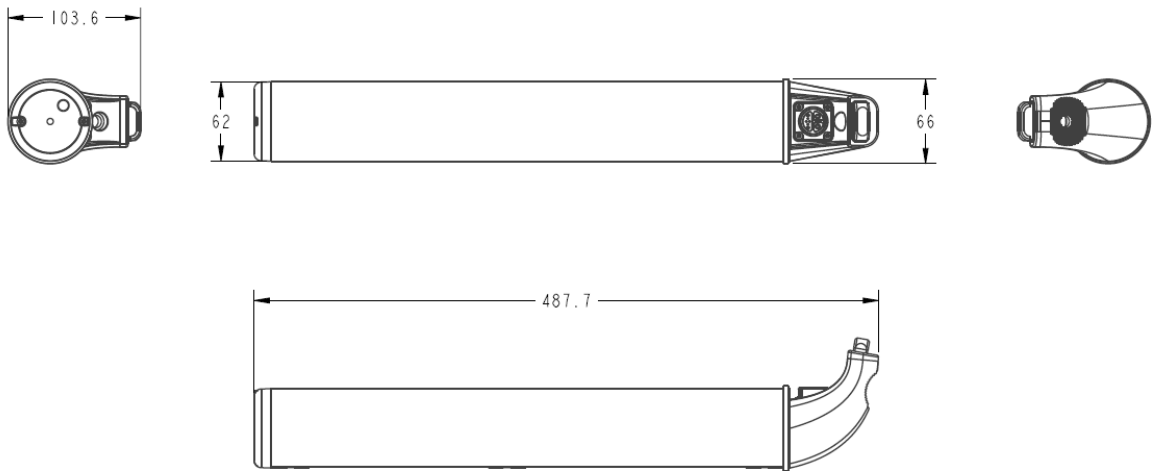

Battery (Unit: mm)

Circuit diagram:

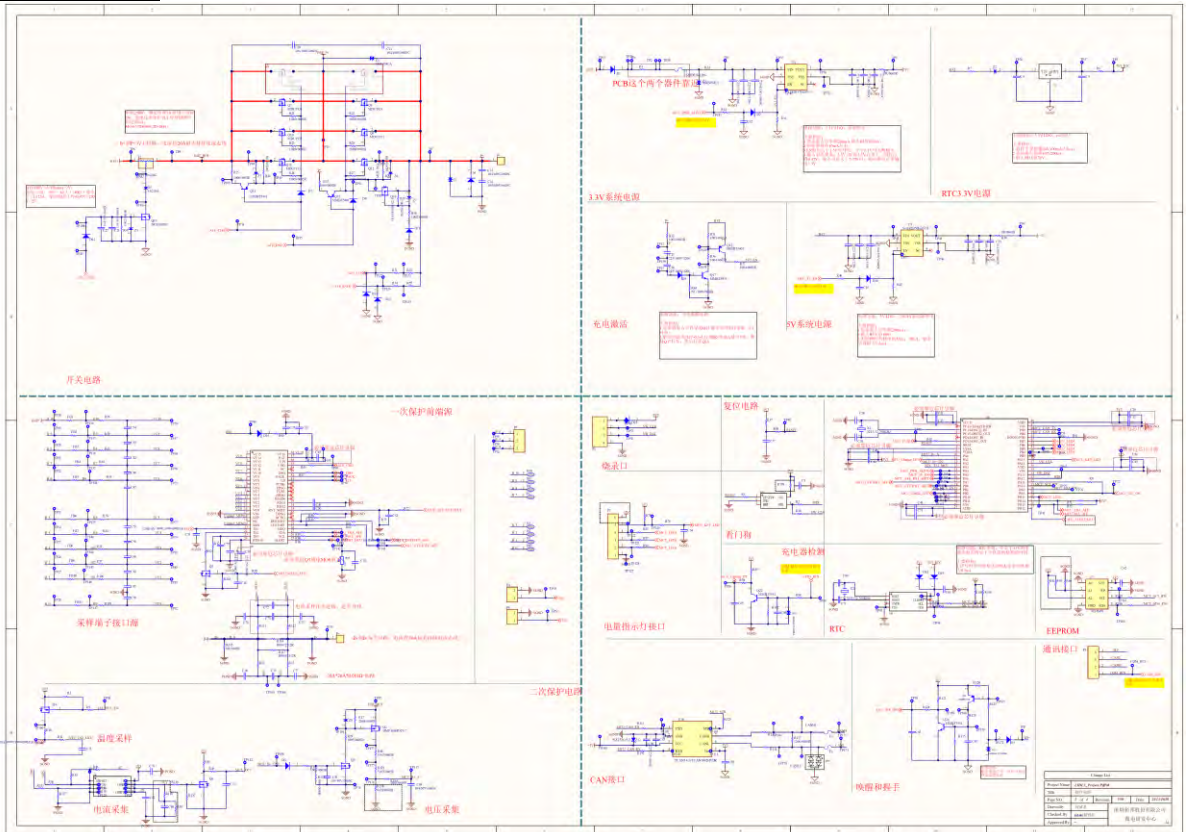

EN 50604-1: 2016+A1: 2021			
Clause	Requirement + Test	Result - Remark	Verdict
5	General requirements		P
	This clause of ISO 12405-3:2014 is applicable except as follows:		P
5.1	General		P
	Replacement:		
5.1.101	General conditions		P
	A battery pack/system to be tested according to this standard shall fulfil the following requirements:		P
	– Electrical safety design shall be approved according the requirements given in ISO 6469-1 and ISO 6469-3		P
	– The necessary documentation for operation and needed interface parts for connection to the test equipment (i.e. connectors, plugs including cooling) shall be delivered together with the DUT	Documentation provided by manufacturer.	P
	– A battery system shall enable the specified tests, e.g. by specified test modes implemented in the BCU/BMS, and shall be able to communicate with the test bench via e.g. common communication buses		P
	– The DUT may also be equipped with additional sensors, wires, support which are necessary to conduct the specific test or to obtain the required data for such test. Such additional devices shall not influence the result with respect to the intended purpose of the test.		P
5.2	Test sequence plan		P
	This subclause of ISO 12405-3: 2014 is applicable		P
	For details on test sequences and numbers of samples, see Annex GG, Table GG.1.		P
5.3	Preparation of the DUT for testing		P
	This subclause of ISO 12405-3:2014 is applicable.		P
5.4	Pre-conditioning cycles		P
	This subclause of ISO 12405-3:2014 is applicable.		P
5.5	General safety requirements		P
	This subclause of ISO 12405-3:2014 is applicable.		P
5.101	Battery pack/system requirements		P
	For cell: Compliance with UN Recommendations on the Transport of Dangerous Goods - Manual of Tests and Criteria: Section 38.3, and one of the following:	Cell UN 38.3 report provided.	P

EN 50604-1: 2016+A1: 2021			
Clause	Requirement + Test	Result - Remark	Verdict
	– relevant Li-ion battery cell standard EN 62660-3; or – relevant Li-ion battery cell standard EN 62133-2.	IEC 62133-2:2017 CB certificate and report provided.	P
	For BMS: The BMS shall provide		P
	– controlling of charging/discharging process;		P
	– active or passive protective devices		P
	– protective devices as part of BMS		P
	– compatibility check between battery system and connected equipment.		P
	Enclosure of removable battery packs/systems shall provide at least		P
	– mechanical strength to withstand stress caused by normal use and rough handling;		P
	– sufficiently resistant to degradation caused by sunlight radiation;		P
	– reducing the possibility of ignition and spread of flame;		P
	–providing suitable insulation characteristics, at least basic insulation according to IEC 60664- 1:2007		P
	– protection against ingress of foreign objects and water: IP54	IP54 tested and complied.	P
	– the battery pack/system housing constructed in a way that it cannot be opened without the use of tools and any opening should be easily detectible by a broken seal;		P
	For Assembled removable battery system		P
	– for RESS connector or RESS inlet, standard plug and standard socket-outlets and connectors (e.g. IEC 60320 series) shall not be used;		P
	– the RESS connector shall prevent reverse polarity connections		P
	– the RESS connector shall not have a simple shape, which cannot grant a sufficiently unique mechanical profile (see NOTE 1);		P
	– an internal switch in the DC power circuit of the battery pack/system, controlled by the BMS, able to interrupt all power flow and ensure safety. The switch shall only be closed after a successful compatibility check;		P
	–a compatibility check between battery system and EV supply equipment shall be performed based on at least two of the following:		P
5.102	Battery pack/system safety considerations		P

EN 50604-1: 2016+A1: 2021			
Clause	Requirement + Test	Result - Remark	Verdict
	All tests, which could be influenced by integration of the battery pack/system into the vehicle (e.g. installation into the frame), shall be carried out with the battery pack/system integrated into the vehicle.	Removable EESS, tested with battery pack only.	N/A
	Removable RESS can be tested without the vehicle or parts of it.		P
	In a battery system consisting of two or more battery packs, each battery pack shall be isolated from each other battery pack by thermal isolation, protective barrier, or protective separation, or a stable gap from other battery packs and the enclosure.	Single battery pack.	N/A
	Wire ways shall be smooth and free from sharp edges, and internal wiring shall be routed, supported, clamped or secured in a manner that reduces the likelihood of excessive strain on wire and on terminal connections.		P
	Holes through which insulated wires pass shall have smooth well-rounded surfaces or be provided with bushings.		P
	Wire insulation shall be sufficient to withstand the maximum anticipated voltage, current, temperature, altitude, humidity requirements and mechanical stress.		P
	In connections by soldered terminations, the conductor shall be held in position additionally to the soldering to maintain it in position.		P
	Connection to the cells shall be made according to the specification of the cell manufacturer in a manner that does not result in damage to the cells.		P
	The enclosure of a removable battery pack/system shall provide at least IP54 according to EN 60529:1991.	Tested complied.	P
	A crush test is not required if the battery system in the EV is secured by double mechanical protection (e.g. latch and mechanical cover). Compliance shall be verified by inspection of a test report. Only for battery systems permanently fixed to vehicles with maximum speed more than 45 km/h, crash tests which may replace a crush test are defined by the countries where the vehicles are released.	Crush test on EESS conducted.	N/A
5.102.2	Precautions when conducting tests		P
5.103	Options for tests for evaluation of protective devices		P
5.103.1	General		P
5.103.2	Evaluation option 1:		N/A
	Active protective devices bypassed.		N/A
5.103.3	Evaluation option 2:		P

EN 50604-1: 2016+A1: 2021			
Clause	Requirement + Test	Result - Remark	Verdict
	All protective circuits operating.	ISO 13849 report provided, option 2 used for related tests.	P
	All protective devices shall be proven to be reliable according to the EN 61508 (series) or EN ISO 13849 (all parts) performance level c.		P
5.103.4	Evaluation Option 3		N/A
	Active protective devices in operation with all single faults injected and tested separately		N/A
	If protective devices which are not proven to reach performance level c according to the EN ISO 13849 (all parts) or EN 61508 (series) are used, a design review shall be performed to identify failure modes taking in consideration also EMC conditions.		N/A
5.104	Voltage classes		P
	Battery packs/systems according to this document can be rated for voltage class A or voltage class B up to a maximum voltage of 200 V DC	Max working voltage below 60Vdc, rated as Class A.	P
5.105	Requirements for the BMS		P
	The BMS evaluates and controls the condition of each cell, cell block and battery pack/system, and it maintains cells, cell blocks and battery pack/systems within the specified cell operating region as defined by the cell manufacturer (See IEC 62619:2017, Annex A).	BMS controls the cell within the specified cell operating region.	P
	Key factors of the cell operating region are voltage, temperature and current. (See IEC 62619:2017, Figures A.1 and A.2)		P
	Battery systems intended to be used in conjunction with products or systems described in the IEC/TS 61851-3 series shall provide a BMS according to IEC/TS 61851-3-4.		N/A
5.106	Charging/discharging		P
5.107	Test result explosion		P
5.108	Test result fire		P
5.109	Test result leakage		P
5.110	Flammability of non-metallic materials		P
	Non metallic materials employed for the cell holder and outer enclosures of a battery pack/system, which are used in an amount of > 1 cm ³ shall have a minimum flame rating of V-2 in accordance with IEC 60695-11-10.		P
6	Mechanical tests		P
	Replacement:		N/A
6.101	Vibration		P

EN 50604-1: 2016+A1: 2021			
Clause	Requirement + Test	Result - Remark	Verdict
	Peak acceleration of logarithmic sweep from 7 Hz to 18 Hz (gn).....:	1gn	P
	Frequency when peak acceleration reached 8 gn (Hz).....:	50Hz	P
	Peak acceleration of logarithmic sweep from ca. 20 Hz/50 Hz to 200 Hz (gn).....:	8gn	P
	Number of cycles per perpendicular direction.....:	12	P
	Duration of each cycle per perpendicular direction (min).....:	180min	P
	Number of perpendicular directions tested.....:	3	P
	Ratio of mass of battery after and before the test (%).....:	(see appended table)	P
	Criteria: no leakage, no rupture, no explosion or fire, voltage class B DUT shall maintain an isolation resistance of at least 100Ω/V. voltage class A or B DUT shall maintain an isolation resistance of at least 100 Ω/V	(see appended table)	P
6.102	Mechanical shock		P
	All mounting surfaces of battery supported when secured to testing equipment		P
	Peak acceleration of half-sine shock (gn).....:	150	P
	Pulse duration of half-sine shock (ms).....:	6	P
	Number of cycles per perpendicular direction in positive direction.....:	3	P
	Number of cycles per perpendicular direction in negative direction.....:	3	P
	Number of perpendicular directions tested.....:	18	P
	Ratio of mass of battery after and before the test (%).....:	(see appended table)	P
	Criteria: no leakage, no rupture, no explosion or fire, voltage class B DUT shall maintain an isolation resistance of at least 100Ω/V.	(see appended table)	P
6.103	Drop Test		P
	DUT shall be placed in a climate chamber at the lowest operation temperature specified by the supplier for minimum 2h until thermal equilibrium. Adjust the SOC to 100 % before starting the Drop test	Prepared as required.	P
	Drop height (m).....:	1m	P
	Number of drops.....:	6	P
	Criteria: no leakage, rupture, fire or explosion after 6h post-test observation		P

EN 50604-1: 2016+A1: 2021			
Clause	Requirement + Test	Result - Remark	Verdict
6.104	Thermoplastic materials exposed to sunlight		P
	The test has to be performed without cells in the housing, but the temperature inside the housing shall be recorded.		N/A
	All non-metallic materials exposed to UV radiation (sunlight) shall be tested according to EN ISO 4892-2, Method A, Cycle 1 providing a total test period of 500 h.		N/A
	For compliance, enclosures constructed of metals entirely coated by synthetic material, the adherence of the synthetic material shall have a minimum retention of category 3 according to EN ISO 2409:2013.		N/A
	This test does not need to be carried out if the original manufacturer can provide data from the material supplier to demonstrate that material of the same type and thickness or thinner complies with this requirement. NOTE 2 A test according to UL 746C:2018 is seen as equivalent	The enclosure material meet requirements of UL 746C: 2018	P
7	Climatic tests		P
7.1	Dewing (temperature change)		P
	This subclause of ISO 12405-3:2014 is applicable.		P
7.2	Thermal shock cycling		P
	This subclause of ISO 12405-3:2014 is applicable.		P
	Criteria: no leakage or battery enclosure rupture, fire, or explosion, and voltage class B DUT shall maintain an isolation resistance of at least 100 Ω/V		P
8	Simulated vehicle accidents		P
8.101	Crush test		P
	Description of orientations tested	Longest side and narrow side	P
	Speed of stamp (mm/s).....:	15mm/s	P
	Crush force (kN).....:	(see appended table)	P
	Battery voltage (V).....:	(see appended table)	P
	Battery enclosure temperature ($^{\circ}C$).....:	(see appended table)	P
	Venting or explosion of battery	No venting or explosion occurred.	P
	Criteria: no rupture, fire.		P
8.3	Water immersion		P
	Immerse the DUT in ambient temperature salt water (5 % by weight NaCl in H ₂ O) for a minimum of 2 h or until any visible reactions have stopped	Tested complied.	P

EN 50604-1: 2016+A1: 2021			
Clause	Requirement + Test	Result - Remark	Verdict
	DUT can be tested by vehicle emulated condition	Tested on battery pack.	N/A
	Criteria: no fire or explosion during the test and for a 1h post-test observation period.		P
8.4	Exposure to fire	Not applicable, not used for vehicles with passenger compartment.	N/A
	This subclause of ISO 12405-3:2014 is only applicable for battery systems to be used in vehicles with passenger compartments which can be closed or locked or in vehicles where the use of safety belts is compulsory		N/A
	Criteria: no explosion		P
8.102	Over-temperature condition test		P
	The temperature of the DUT shall be set to 50°C, that is 10°K above the maximum temperature for performance testing (40°C).	Tested complied.	P
	A rest period of 2 h or until thermal equilibration has been reached shall be performed.		P
	Perform a discharge and then a charge at the maximum current rate according to the specifications of the supplier.		P
	Repeat the discharge and charge cycle until the intervention of the over-temperature protection measure or at the thermal stabilization of the DUT. The DUT's temperature shall be monitored by the measurement devices which are integrated in the DUT by the supplier.	Charge and discharge until thermal stabilization of the DUT.	P
	Criteria: no leakage, rupture, fire, or explosion.		P
8.103	Under-temperature condition test	Tested complied.	P
	Perform a discharge according to the specification of the supplier to 80 ± 5 % SOC		P
	The DUT shall then be placed in a climate chamber. The temperature shall be set 10 K under the low temperature limit set by the supplier. A rest period of 2 h or until thermal equilibration has been reached		P
	Perform a charge at the maximum current rate according to the specification of the supplier		P
	This test shall be performed for option 1, 2 or 3.	Option 2 performed.	P
	Criteria: not accept any charge or discharge under these conditions, no rupture, explosion, venting or fire.		P
9.1	Short circuit		P
9.1.101.1	Option 1		N/A

EN 50604-1: 2016+A1: 2021			
Clause	Requirement + Test	Result - Remark	Verdict
	An appropriately sized conductor directly contacted to the battery cells of (20 +0/-10) mΩ shall be used to apply a “hard short” in less than one second for 10 min, or until another condition occurs that prevents completion of the test (e.g. component melting)..		N/A
	The test shall be performed without integrated, passive and active protective devices for short circuit protection operational		N/A
9.1.101.2	Option 2 or Option 3		P
	An appropriately sized conductor of (20 +0/-10) mΩ shall be used to apply a “hard short” in less than one second for 10 min, or until another condition occurs that prevents completion of the test (e.g. component melting).	Option 2 performed.	P
	The test shall be performed with integrated, passive and active protective passive short circuit protection devices operational		P
	Criteria: The overcurrent protection function for option 2 or option 3, if any, shall disconnect the short circuit current. No disassembly or explosion, the temperature of the battery casing shall not exceed 150 °C within 6 h.		P
9.101	Leakage current of a battery system while switched-off		P
	a) a steady-state current flowing between simultaneously accessible conductive parts not exceeding the threshold of perception, 0,5 mA a.c. or 2 mA d.c. under normal operating conditions; values not exceeding the threshold of pain 3,5 mA a.c. or 10 mA d.c. may be specified under abnormal or fault conditions;	Complied with the requirement.	P
	b) for stored energy available between simultaneously accessible conductive parts the following values are proposed according to IEC/TS 60479-2:2007, Figure 19: 1) + 0,5 mJ corresponding to the threshold of pain and 2) +,5 uJ corresponding to the threshold of perception.	SELV circuit, complied with the requirement.	P
10	System functionality tests		P
10.1	Overcharge protection		P

EN 50604-1: 2016+A1: 2021			
Clause	Requirement + Test	Result - Remark	Verdict
	The DUT shall be charged at a constant current which is agreed between the supplier and customer, using a supply voltage sufficient to maintain the before described current throughout the duration of the test. The voltage shall not exceed 1,2 times the maximum allowed cell voltage as defined by the supplier unless EV supply equipment is limited in voltage Then the voltage applied to the DUT shall be set to the maximum output voltage of the EV supply equipment that can occur.		P
	This test shall be performed for option 1, option 2 or option 3	Option 2 used.	P
	Overcharge until the DUT explodes, vents or the temperature of the outside of the enclosure reaches the steady-state conditions or returns to the ambient temperature.		P
	Criteria: no rupture, explosion, venting or fire		P
10.2	Over-discharge protection		P
	For Option 2 or Option 3: ISO 6469-1:2019, 5.5.3 is applicable	Option 2 used.	P
10.3	Loss of thermal control/cooling		P
	This clause of ISO 12405-3:2014 is applicable.		P
10.4	Deep discharge protection		P
10.4.102.1	Test procedure Option 1		N/A
10.4.102.2	Test procedure Option 2 or 3	Option 2 used.	P
Annex AA	Battery systems and related parts		N/A
Annex BB	General Marking requirements		P
BB.1	Marking and instructions		P
BB.1.1	Removable (RESS) battery systems (packs) marking		P
	Each removable (RESS) battery system (pack) shall carry clear and durable marking on the outer enclosure providing all of the following information in BB.1.2, if applicable:		P
	-graphical symbol for rechargeable Li or Li-ion	See page 4.	P
	- graphical symbol Crossed Wheelie Bin	See page 4.	P
	- polarity of terminals (unless standardized, polarized connectors are used);	Polarized connectors used.	N/A
	- nominal voltage;	36.9V marked.	P
	- maximum charge current/voltage and maximum discharge current in A/V	See page 4.	P
	- rated capacity in Ah, and rated energy in Wh	9.6Ah, 354.24Wh marked.	P

EN 50604-1: 2016+A1: 2021			
Clause	Requirement + Test	Result - Remark	Verdict
	- name, trade mark or identification mark of the supplier or responsible vendor;	See page 4.	P
	- serial number;	See page 4.	P
	- model or type reference (optional);	Model name marked.	P
	- graphical symbol caution;	See page 4.	P
	- graphical symbol read operator's manual;	See page 4.	P
	- graphical symbol dangerous voltage (for voltage class B);	Class A only.	N/A
	- graphical symbol hot surface (if the temperature exceeds 60°C);	Not exceed 60°C	N/A
	- graphical symbol keep away from open flame and great heat;		P
	- graphical symbol danger of explosion and fire due to short circuit, overheating or other electrical/mechanical misuse;		P
	- for Li-ion battery systems, text transport under UN-T 38-3		P
	- symbol BATSO (optional)		N/A
	- text: "Do not open", "Do not expose to water", "Damaged batteries are not allowed to transport"(optional).		P
BB.1.2	Graphical symbols		P
BB.2	Instructions		P
BB.3	Instructions for built-in battery system		P
BB.4	Language		P
BB.5	Label test	Tested complied.	P
BB.6	Markings		P

1.3	TABLE: Subsystems				P
Object/part no.	Manufacturer/ trademark	Type/model	Technical data	Standard	Mark(s) of conformity
PCB	SHENZHEN UNIWELL CIRCUITS CO LTD	UW01	130°C, V-0	UL 94 UL 796	UL E314500
PCB (Alternative 1)	VICTORY GIANT TECHNOLOGY (HUIZHOU) CO LTD	SH	130°C, V-0	UL 94 UL 796	UL E248779
PCB (Alternative 2)	Interchangeable	Interchangeable	130°C, V-0	UL 94 UL 796	UL Approved
IC (U1)	ABLIC Inc.	S-1142B33I- E6T1U	V _{IN} : 3.0V to 50V, V _{OUT} : 3.3 V±1.0%, T _{opr} : -40°C to 85°C	--	Tested with appliance
IC (U3)	ABLIC Inc.	S-1142B50I- E6T1U	V _{IN} : 3.0V to 50V, V _{OUT} : 5V±1.0%, T _{opr} : -40°C to 85°C	--	Tested with appliance
IC (U4)	3PEAK INCORPORATE D	TPV6823S-TR	V _{CC} : -0.3V to 6V, Output Current: 20mA, T _A : -40°C to 125°C	--	Tested with appliance
IC (U5)	Nations Technologies Inc	N32L406CBL7	V _{IN} : 1.8V to 3.6V, T _A : -40°C to 105°C	--	Tested with appliance
IC (U6)	Texas Instruments Incorporated	BQ7694202PFB R	V _{BAT} : 4.7V to 55V, T _A : -40°C to 85°C	--	Tested with appliance
IC (U9)	Texas Instruments Incorporated	TLV2379IDR	V _{IN} : 1.8V to 5.5V, T _A : -40°C to 125°C	--	Tested with appliance
MOSFET (Q7, Q8, Q9, Q10, Q11, Q12)	Wuxi NCE Power Semiconductor Co., Ltd	NCEP040N85G	V _{DS} : 85V, V _{GS} : ±20V, I _D : 130A, T _{STG} : -55°C to 150°C	--	Tested with appliance
MOSFET (Q19)	Wuxi NCE Power Semiconductor Co., Ltd	NCE0103M	V _{DS} : 100V, V _{GS} : ±20V, I _D : 3A, T _{STG} : -55°C to 150°C	--	Tested with appliance
PTC (F1, F3, F4)	FUZETEC TECHNOLOGY CO LTD	FSMD016-1206- R	V _i : 48V, V _{max} : 48V, I _n : 160mA, I _t : 450, I _{max} : 100 I _{sc} : 100, T _{moa} : 85°C	UL 1434 EN 60738- 1:1999 EN 60738-1- 1:1999	UL E211981 TÜV R 50090556

FUSE (F2)	Wayon Electronics co., Ltd	WPF30A14K	Operation Current: 30A, Maximum Voltage: 80V	UL 248-1 UL 248-14	UL E311435
NTC (R11)	CHENZHOU AMPRON Sensing TechnologyCo., Ltd	WPF30A14K_30 A/80VDC	R ₂₅ : 10KΩ±1%, B _{25/85} : 3435K±1%, -40°C to 150°C	--	--
Cell	LG ENERGY SOLUTION, LTD.	INR21700M50LT	3.69Vdc, 4800mAh	IEC 62133-2:2017	CB Certificate No.: DK-112813-UL, DK-112813-M1-UL and DK-112813-M2-UL
Plastic cell support	KINGFA SCI & TECH CO LTD	JH960 HT (M1) (sr)	PC+ABS, V-0, thickness, 1.5mm	UL 94 UL 746	UL E171666
Plastic cell support (Alternative 1)	KINGFA SCI & TECH CO LTD	JH960 HT (M1) (ccc) (##)(sr)	PC+ABS, V-0, thickness, 1.5mm	UL 94 UL 746	UL E171666
Plastic cell support (Alternative 2)	KINGFA SCI & TECH CO LTD	JH960-HT (M1) (ccc) (##)(sr)	PC+ABS, V-0, thickness, 1.5mm	UL 94 UL 746	UL E171666
Wire (discharge)	DONGGUAN ZHONGZHEN NEW ENERGY TECHNOLOGY CO.,LTD	3135	16AWG, 200°C, 600Vac	UL 758	UL E355578
Wire (discharge) (Alternative)	Interchangeable	Interchangeable	Min.16AWG, 200°C, 600Vac	UL 758	UL Approved
Connector (Charge & discharge)	Changzhou Amass Electronics Co Ltd	XT30U-M	500V, 15A, PA66	UL 1977	UL E482722
Connector (Charge & discharge) (Alternative)	Interchangeable	Interchangeable	500V, 15A, PA66	UL 1977	UL Approved
Plastic enclosure	KINGFA SCI & TECH CO LTD	JH98 (dd)-HT(M1) (ddd) (##) (f1)	PC+ABS, V-0, Min. thickness: 1.5mm, 100°C	UL 94 UL 746	UL E171666

Metal Enclosure	Kunshan Mingjie Hardware Electronics Co.,Ltd.	TB01	6063-T5, 2.0mm	--	--
Supplementary information:					

6.101		TABLE: Vibration					P
Sample no.	OCV at start of test (Vdc)	Mass at start of test (g)	OCV after of test (Vdc)	Mass after of test (g)	Mass Loss (%)	Results	
A003824149-001	41.0	2366.4	35.0	2366.0	0.017	P	
A003824149-002	41.0	2368.4	34.9	2368.4	0.000	P	
A003824149-003	41.4	2368.2	34.9	2368.2	0.000	P	

Supplementary information:
No leakage. No fire. No explosion. No rupture, the DUT accept discharge under the conditions, Isolation resistance > 100Ω/V.

6.102		TABLE: Mechanical shock					P
Sample no.	OCV at start of test (Vdc)	Mass at start of test (g)	OCV after of test (Vdc)	Mass after of test (g)	Mass Loss (%)	Results	
A003824149-001	41.3	2366.0	41.3	2366.0	0.000	P	
A003824149-002	40.4	2368.5	40.2	2368.0	0.021	P	
A003824149-003	40.4	2368.0	40.3	2368.0	0.000	P	
A003824149-004	41.3	2366.0	41.3	2366.0	0.000	P	

Supplementary information:
No leakage. No fire. No explosion. No rupture.

6.103		TABLE: Drop test					P
Sample no.	OCV at start of test (Vdc)	Mass at start of test (g)	OCV after of test (Vdc)	Mass after of test (g)	Mass Loss (%)	Results	
A003824149-001	41.2	2366.0	41.2	2366.0	0.000	P	
A003824149-002	40.3	2368.5	40.2	2366.5	0.084	P	
A003824149-003	40.4	2368.5	40.3	2368.0	0.021	P	

Supplementary information:
No leakage. No fire. No explosion. No rupture.

7.1	TABLE: Dewing (temperature change)			P
Sample no.	Mass at start of test (g)	Mass after of test (g)	Results	
A003824149-005	2365.4	2366.0	P	
A003824149-006	2361.2	2361.4	P	
A003824149-007	2358.2	2358.6	P	
Supplementary information: No leakage. No fire. No explosion. No rupture.				

7.2	TABLE: Thermal-shock cycling			P
Sample no.	Mass at start of test (g)	Mass after of test (g)	Results	
A003824149-005	2366.0	2365.6	P	
A003824149-006	2361.4	2361.4	P	
A003824149-007	2358.6	2358.8	P	
A003824149-008	2362.0	2362.0	P	
Supplementary information: No leakage. No fire. No explosion. No rupture.				

8.101	TABLE: Crush test				P
Sample no.	Crush Orientation	OCV before test (Vdc)	Maximum force applied (kN)	Max. Temperature rise of enclosure (°C)	Results
A003824149-009	Narrow side	41.2	23.2	24.2	P
A003824149-010	Wide side	40.9	23.2	22.2	P
Supplementary information: No fire. No rupture.					

8.3	TABLE: Water immersion			P
Sample no.	Water temperature (°C)	OCV before test (Vdc)	Results	
A003824149-006	23.8	40.6	P	
A003824149-008	23.8	40.5	P	
Supplementary information: No fire. No explosion.				

8.102		TABLE: Over-temperature condition test				P
Sample no.	Chamber temperature (°C)	Max. charge current (A)	Max. discharge current (A)	Max. Temperature of battery (°C)	Results	
A003824149-011	51.1	3.0	10.0	53.8	P	
A003824149-012	51.1	3.0	10.0	53.7	P	
A003824149-013	51.1	3.0	10.0	53.5	P	
Supplementary information: No leakage. No fire. No rupture. No explosion						

8.103		TABLE: Under-temperature condition test			P
Sample no.	Chamber temperature (°C)	Max. charge current (A)	Max. Temperature of battery (°C)	Results	
A003824149-011	-9.9	4.0	-9.0	P	
A003824149-012	-9.9	4.0	-9.1	P	
A003824149-013	-9.9	4.0	-9.2	P	
Supplementary information: The DUT shall not accept any charge or discharge under these conditions, No leakage. No fire. No rupture. No explosion.					

9.1		TABLE: Short-circuit test				P
Sample no.	Ambient T (°C)	OCV before test (Vdc)	Resistance of circuit (mΩ)	Maximum case temperature rise ΔT (°C)	Component single fault condition	Results
A003824149-005	22.5	41.4	16.94	23.3	--	P
A003824149-006	22.7	40.5	16.75	23.4	--	P
A003824149-007	22.4	40.7	16.29	23.4	--	P
Supplementary information: The overcurrent protection function disconnects the short circuit current. The DUT not exhibit any evidence of: disassembly or fire. The temperature of the battery casing does not exceed 150 °C within 6 h						

10.1					P
TABLE: Overcharge protection					
Sample no.	Ambient temperature (°C)	Charge Voltage (V)	Max. charge current (A)	Max. Temperature of battery (°C)	Results
A003824149-011	24.8	50.4	19.2	26.2	P
A003824149-012	24.8	50.4	19.2	26.0	P
A003824149-013	24.8	50.4	19.2	26.2	P
Supplementary information: No rupture, explosion, venting or fire					

10.2					P
TABLE: Over-discharge protection					
Sample no.	Ambient temperature (°C)	Discharge Voltage (V)	Discharge current (A)	Max. Temperature of battery (°C)	Results
A003824149-014	22.2	29.35	3.2	26.0	P
A003824149-015	22.2	29.27	3.2	25.5	P
A003824149-016	22.2	29.06	3.2	25.3	P
Supplementary information: No rupture, explosion, venting or fire					

10.3				P
TABLE: Loss of thermal control/cooling				
Sample no.	Chamber Max. temperature (°C)	Max. Temperature of battery (°C)	Test Duration (hours)	Results
A003824149-005	50.1	45.2	0.22	P
A003824149-007	50.1	45.7	0.23	P
A003824149-014	50.1	45.2	0.29	P
Supplementary information: The thermal control or cooling function interrupt the charge and discharge current. No leakage. No fire. No rupture. No explosion.				

10.4	TABLE: Deep discharge protection		P
Sample no.	Single cell voltage before charge	Results	
A003824149-014	1.54V	P	
Supplementary information: The analysis of the functionality of the BMS demonstrate that all the aspects of Test 1 are fulfilled and that they prevent battery pack/system from being charged and permanently disable it for further use.			

—End of Report—

	Eq. No.	Name	Manufacturer	Model No.	Date of Calibration	Date of next Calibration
<input checked="" type="checkbox"/>	1.903	Hydraulic shock tester	SuZhou DongLing Vibratioin Testing Equipment Ltd	SY10-50	2024.01.09	2025.01.08
<input checked="" type="checkbox"/>	1.908	Electro-dynamic vibration test system	LDS Test and Measurement Ltd	V850-440-LPT600/SPA32K	2024.10.10	2025.10.09
<input checked="" type="checkbox"/>	1.909	Steel ruler(2 m)	ZhengJiang YongKang Shiya Bright Measuring Tool Factory	2m	2024.06.22	2025.06.21
<input checked="" type="checkbox"/>	1.997	DC Electronic Load	ITECH	IT8812C 120V/60A/250W	2024.09.12	2025.09.11
<input checked="" type="checkbox"/>	1.998	DC Electronic Load	ITECH	IT8812C 120V/60A/250W	2024.09.21	2025.09.20
<input checked="" type="checkbox"/>	1.999	DC Electronic Load	ITECH	IT8812C 120V/60A/250W	2024.09.12	2025.09.11
<input checked="" type="checkbox"/>	2.000	DC Electronic Load	ITECH	IT8513C 120V/120A/600W	2024.09.12	2025.09.11
<input checked="" type="checkbox"/>	2.002	DC Electronic Load	ITECH	IT8513C 120V/120A/600W	2024.09.12	2025.09.11
<input checked="" type="checkbox"/>	2.023	Resistance Meter	HIOKI	RM3544	2024.09.21	2025.09.20
<input checked="" type="checkbox"/>	2.052	Auto Range DC Power Supply	ITECH	IT6952A 60V/25A/600W	2024.05.08	2025.05.07
<input checked="" type="checkbox"/>	2.053	Auto Range DC Power Supply	ITECH	IT6952A 60V/25A/600W	2024.05.08	2025.05.07
<input checked="" type="checkbox"/>	2.054	Auto Range DC Power Supply	ITECH	IT6952A 60V/25A/600W	2024.09.12	2025.09.11
<input checked="" type="checkbox"/>	2.064	Thermal cycling chamber	YinHe(ChongQing) Testing Equipment Co., Ltd.	KWGDS6025IIF	2024.09.21	2025.09.20
<input checked="" type="checkbox"/>	2.180	Midi logger	Graphtec corporation	GL-240	2024.09.21	2025.09.20
<input checked="" type="checkbox"/>	2.181	Midi logger	Graphtec corporation	GL-240	2024.09.21	2025.09.20
<input checked="" type="checkbox"/>	2.083	Multimeter	Fluke	179C	2024.05.08	2025.05.07
<input checked="" type="checkbox"/>	2.043	Battery Testing System	NEWARE	CT-4008-10V6A-FA	2024.09.25	2025.09.24
<input checked="" type="checkbox"/>	2.052	Auto Range DC Power Supply	ITECH	IT6952A 60V/25A/600W	2024.05.08	2025.05.07
<input checked="" type="checkbox"/>	2.053	Auto Range DC Power Supply	ITECH	IT6952A 60V/25A/600W	2024.05.08	2025.05.07
<input checked="" type="checkbox"/>	2.054	Auto Range DC Power Supply	ITECH	IT6952A 60V/25A/600W	2024.09.12	2025.09.11
<input checked="" type="checkbox"/>	2.144	Thermal cycling chamber	Guangdong Sanmu Technology Co., Ltd.	SC-800-CD-3	2024.10.10	2025.10.09
<input checked="" type="checkbox"/>	2.148	Weight scale	MTCELL	ACS-M20	2024.05.08	2025.05.07
<input checked="" type="checkbox"/>	2.151	Auto Range DC Power Supply	ITECH	IT6523C	2024.08.08	2025.08.07
<input checked="" type="checkbox"/>	2.152	Auto Range DC Power Supply	ITECH	IT6523C	2024.08.08	2025.08.07
<input checked="" type="checkbox"/>	2.153	Auto Range DC Power Supply	ITECH	IT6523C	2024.08.08	2025.08.07
<input checked="" type="checkbox"/>	2.180	Midi logger	Graphtec corporation	GL-240	2024.09.21	2025.09.20
<input checked="" type="checkbox"/>	2.181	Midi logger	Graphtec corporation	GL-240	2024.09.21	2025.09.20
<input checked="" type="checkbox"/>	2.206	Crush tester	RJD	RJD-ZJ-RT-20T-1000D	2024.09.30	2025.09.29
<input checked="" type="checkbox"/>	G182 4373	Leakage current tester	HIOKI	ST5541	2024.06.24	2025.06.23

) Initial calibration or verification only

Product: Li-ion Battery pack

Type Designation: E36100B-ST1



Picture 1 Front View of battery



Picture 2 Rear View of battery

Product: Li-ion Battery pack

Type Designation: E36100B-ST1

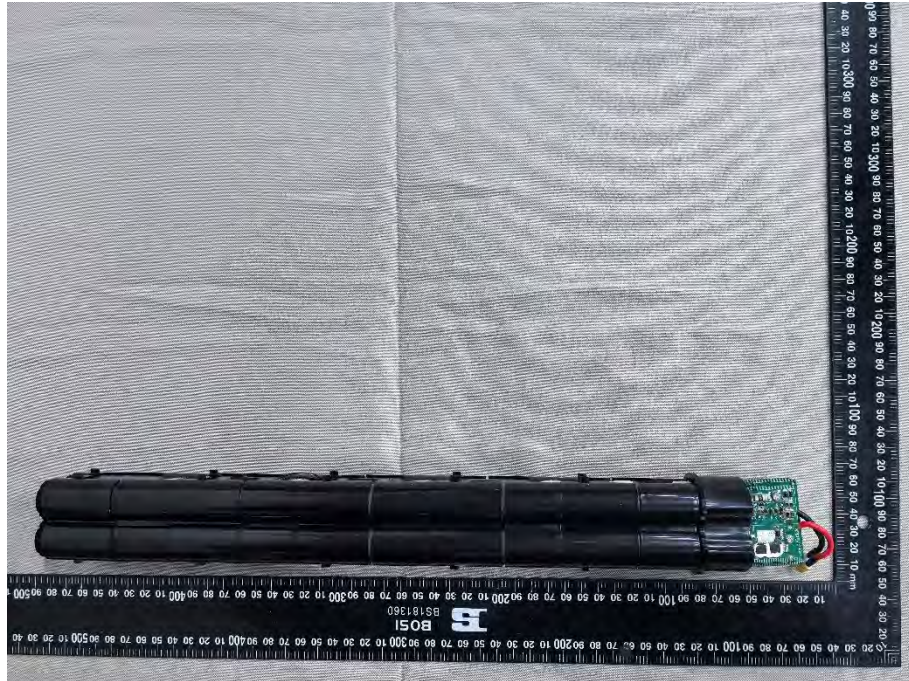

Picture 5 Internal View-2 of battery

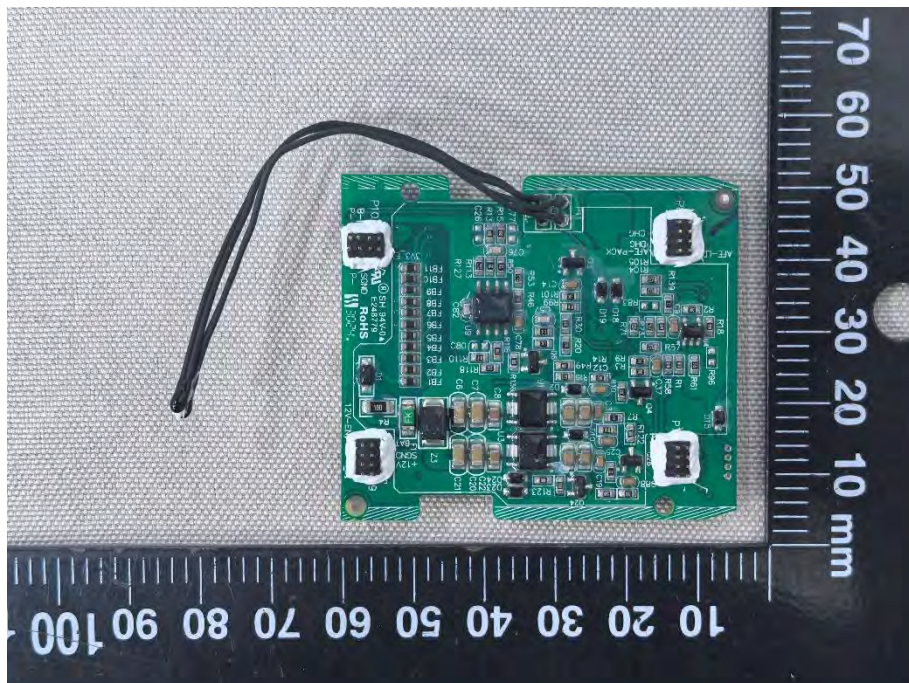

Picture 6 Front View of PCM A

Product: Li-ion Battery pack

Type Designation: E36100B-ST1

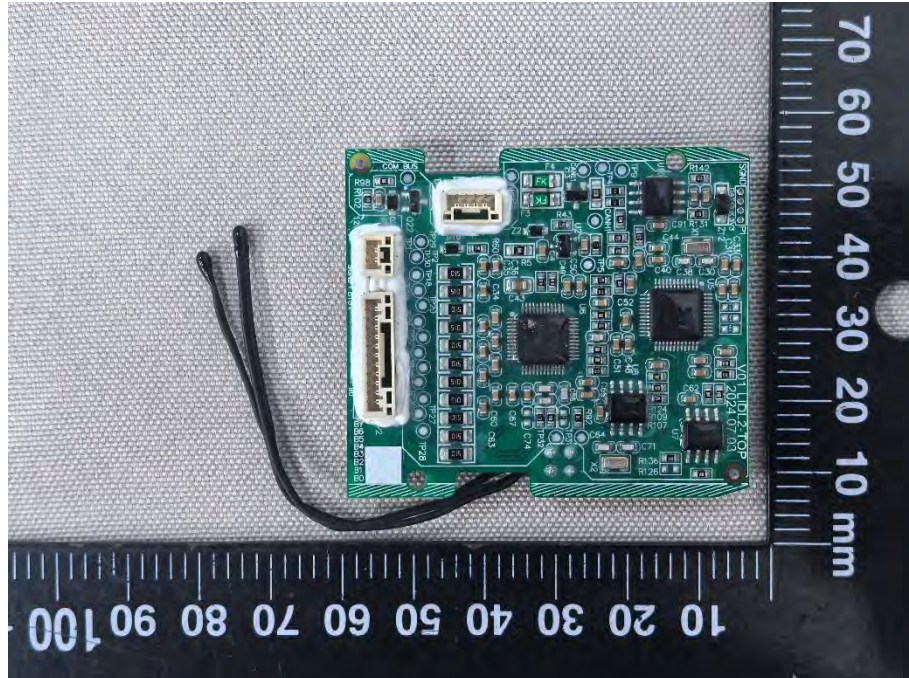

Picture 7 Rear View of PCM A

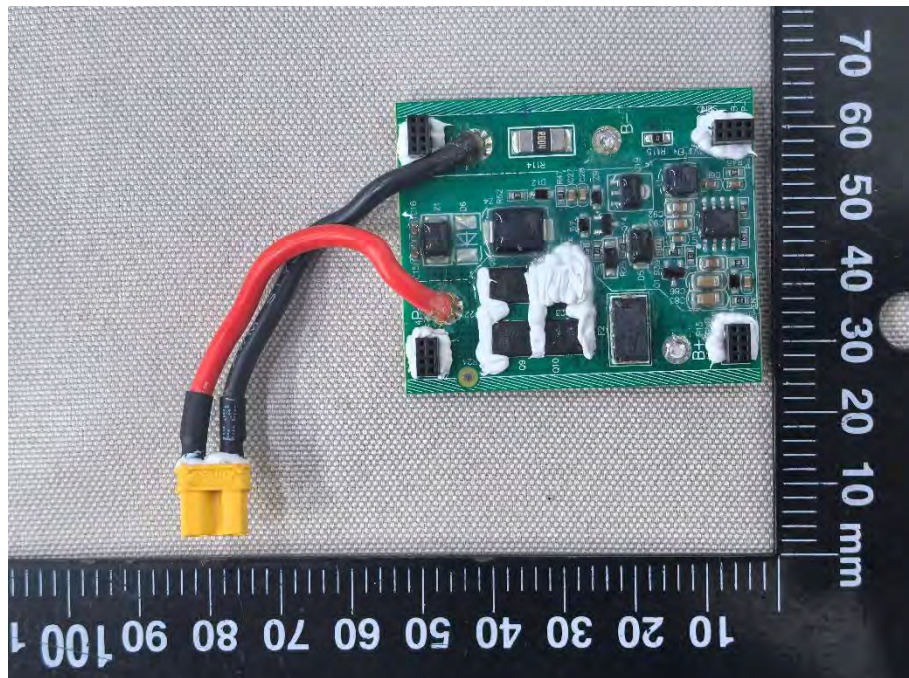

Picture 8 Front View of PCM B

Product: Li-ion Battery pack

Type Designation: E36100B-ST1

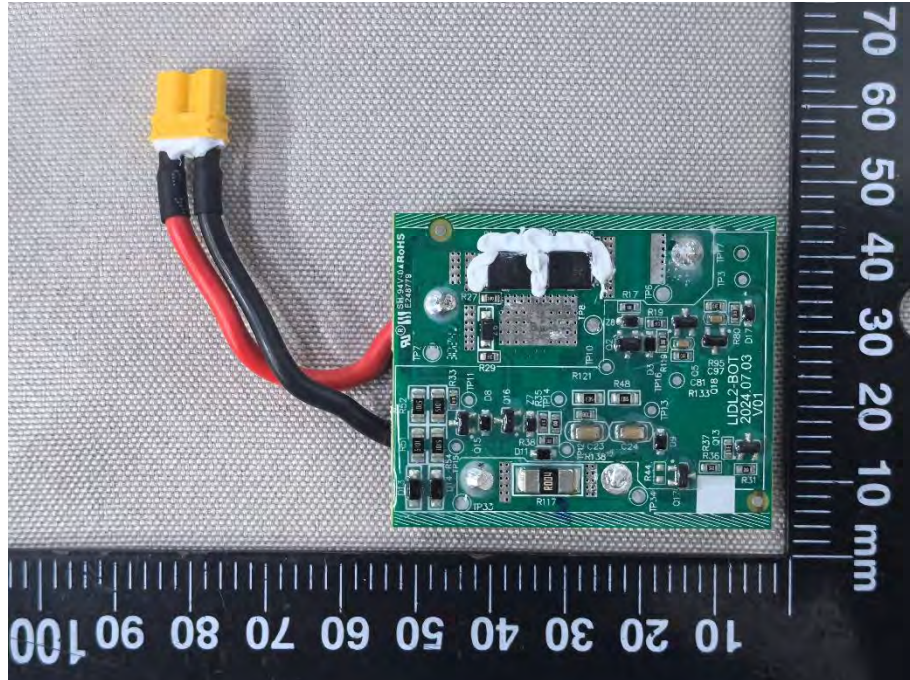

Picture 9 Rear View of PCM B



Picture 10 Front view of the component cell

Product: Li-ion Battery pack

Type Designation: E36100B-ST1



Picture 11 Top view of the component cell

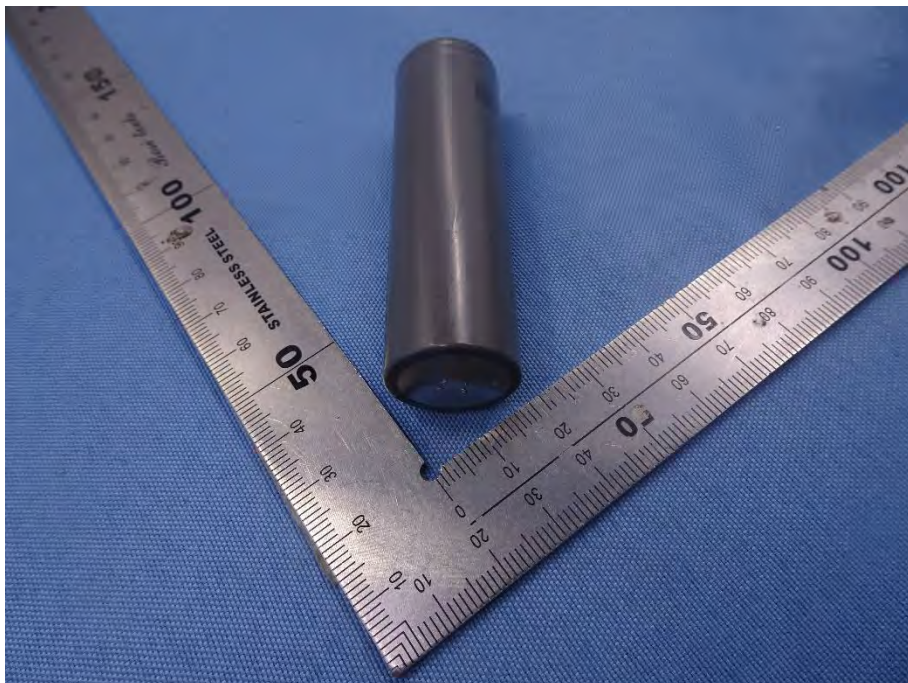

Picture 12 Bottom view of the component cell